

# Introduction to IP Telephony

Why and How Companies are Upgrading Private Telephone Systems to use VoIP Services

*Lawrence Harte*

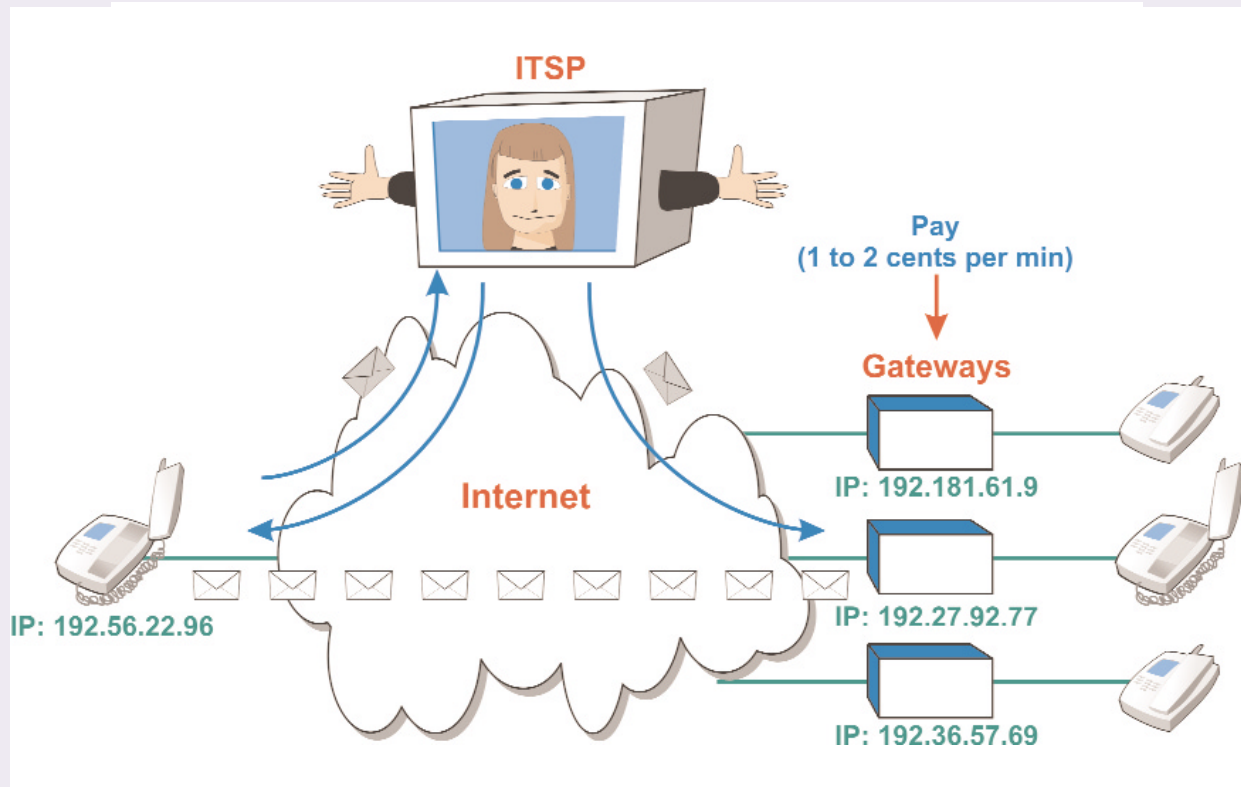

Excerpted From:

Voice Over Data Networks For  
Managers

*With Updated Information*



**ALTHOS Publishing**

## Introduction To IP Telephony

### **ALTHOS Publishing**

Copyright © 2003 by the ALTHOS Publishing Inc. All rights reserved. Produced in the United States of America. Except as permitted under the United States Copyright Act of 1976, no part of this publication may be reproduced or distributed in any form or by any means, or stored in a database or retrieval system, without prior written permission of the publisher.

Some or all of the materials in this ebook also appears in the print version of the book : Voice Over Data Networks for Mangers ISBN: 0-97280532-X

All trademarks are trademarks of their respective owners. We use names to assist in the explanation or description of information to the benefit of the trademark owner and ALTHOS publishing does not have intentions for the infringement of any trademark.

ALTHOS electronic books (ebooks) and images are available for use in educational, promotional materials, training programs, and other uses. For more information about using ALTHOS ebooks and images, please contact Karen Bunn at kbunn@Althos.com or (919) 557-2260

#### **Terms of Use**

This is a copyrighted work and ALTHOS Publishing Inc. (ALTHOS) and its licensors reserve all rights in and to the work. This work may be used for your own noncommercial and personal use; any other use of the work is strictly prohibited. Use of this work is subject to the Copyright Act of 1976, and in addition, this work is subject to these additional terms, except as permitted under the and the right to store and retrieve one copy of the work, you may not disassemble, decompile, copy or reproduce, reverse engineer, alter or modify, develop derivative works based upon these contents, transfer, distribute, publish, sell, or sublicense this work or any part of it without ALTHOS prior consent. Your right to use the work may be terminated if you fail to comply with these terms.

ALTHOS AND ITS LICENSORS MAKE NO WARRANTIES OR GUARANTEES OF THE ACCURACY, SUFFICIENCY OR COMPLETENESS OF THIS WORK NOR THE RESULTS THAT MAY BE OBTAINED FROM THE USE OF MATERIALS CONTAINED WITHIN THE WORK. APDG DISCLAIMS ANY WARRANTY, EXPRESS OR IMPLIED, INCLUDING BUT NOT LIMITED TO IMPLIED WARRANTIES OF MERCHANTABILITY OR FITNESS FOR A PARTICULAR PURPOSE.

ALTHOS and its licensors does warrant and guarantee that the information contained within shall be usable by the purchaser of this material and the limitation of liability shall be limited to the replacement of the media or refund of the purchase price of the work.

ALTHOS and its licensors shall not be liable to you or anyone else for any inaccuracy, error or omission, regardless of cause, in the work or for any damages resulting there from. ALTHOS and/or its licensors shall not be liable for any damages including incidental, indirect, punitive, special, consequential or similar types of damages that may result from the attempted use or operation of the work.

# Table of Contents

WHY CONSIDER VOICE OVER DATA NETWORKS AND INTERNET TELEPHONE SERVICE FOR YOUR COMPANY .....	1
SAVING MONEY WITH VOICE OVER DATA SERVICE .....	2
How Much Can My Company Save .....	3
HOW CAN YOU CALL THROUGH DATA NETWORKS .....	5
Calling through a Dedicated Data Line .....	5
Calling Through the Internet .....	8
CAN I STILL USE MY EXISTING SYSTEMS TELEPHONES .....	10
Does my Staff Have to Change How They Dial .....	11
Telephone Directories for Internet .....	12
MORE CONTROL OVER YOUR TELEPHONE SERVICES .....	13
Instant Activation .....	13
Real Time Accounting and Billing .....	14
NEW REVENUE PRODUCING FEATURES AND SERVICES .....	15
Integrated Sales Information and Telephone Systems .....	15
Increased Geographic Market Using Local Telephone Numbers Throughout the World .....	16
Call Routing Control (Intelligent Call Forwarding) .....	17
Remote Multimedia Communication .....	19
HOW VOICE OVER DATA AND INTERNET TELEPHONE SYSTEMS WORK .....	20
TECHNOLOGY KNOWLEDGE HELPING TO MAKE THE RIGHT CHOICE ....	20
CONVERTING VOICE TO DATA .....	20
Digitization Why and How .....	21
Digital Speech Compression Gaining Efficiency .....	22
SENDING PACKETS .....	24
Packet Routing Methods .....	24
Packet Losses and Effects on Voice Quality .....	25
CONVERTING PACKETS TO TELEPHONE SERVICE .....	27

## Introduction To IP Telephony

Gateways Connect the Internet to Standard Telephones .....	27
MANAGING THE CONNECTIONS .....	28
Gatekeepers Control the Calls .....	29
IP COMMUNICATION SYSTEMS - CONTROL OF SERVICE ACCESS, FEATURES AND BILLING .....	31
INTERNET TELEPHONY SERVICE PROVIDERS (ITSPs) .....	31
INTERNET PROTOCOL CENTREX (IP CENTREX) .....	33
INTERNET PROTOCOL PRIVATE BRANCH EXCHANGE (IPBX) .....	34
VOICE OVER DATA (VOIP) NETWORKS .....	37
SERVERS .....	38
Proxy Servers .....	39
Remote Access Dial In User Server (RADIUS) .....	39
Registrar Servers (RAS) .....	39
Provisioning Servers .....	40
Call Detail Record (CDR) Servers .....	40
Policy Server .....	40
Domain Name Server (DNS) .....	40
GATEWAYS .....	40
Audio Gateways .....	41
Signaling Gateways (SG) .....	41
NETWORK CAPACITY .....	41
NUMBER PORTABILITY KEEPING YOUR TELEPHONE NUMBERS .....	43
NUMBER PORTABILITY .....	45
VOICE QUALITY, SECURITY AND RELIABILITY .....	47
AUDIO QUALITY .....	47
Toll Quality Audio .....	47
Echoes .....	48
Audio Distortion .....	50
SECURITY .....	52
Physical Access .....	52
Authentication .....	54
Encryption .....	55

## Introduction To IP Telephony

RELIABILITY .....	56
Access Device Reliability .....	57
Data Network Reliability .....	58
Data Connection Reliability .....	59
Call Server Reliability .....	60
Feature Operation Reliability .....	62
ADVANCED FEATURES AND SERVICES .....	63
UNIFIED MESSAGING .....	63
ANYWHERE EXTENSIONS .....	65
GLOBAL TELEPHONE NUMBERS .....	67
VIDEOPHONE .....	68
WHITEBOARD .....	69
AUDIO CONFERENCING .....	71
AUDIO CHAT ROOMS .....	73
WEB SEMINARS (WEBINARS) .....	74

# Why Consider Voice Over Data Networks and Internet Telephone Service For Your Company

There are three key reasons why companies are adding to or converting their existing telephone systems to voice over data network capabilities:

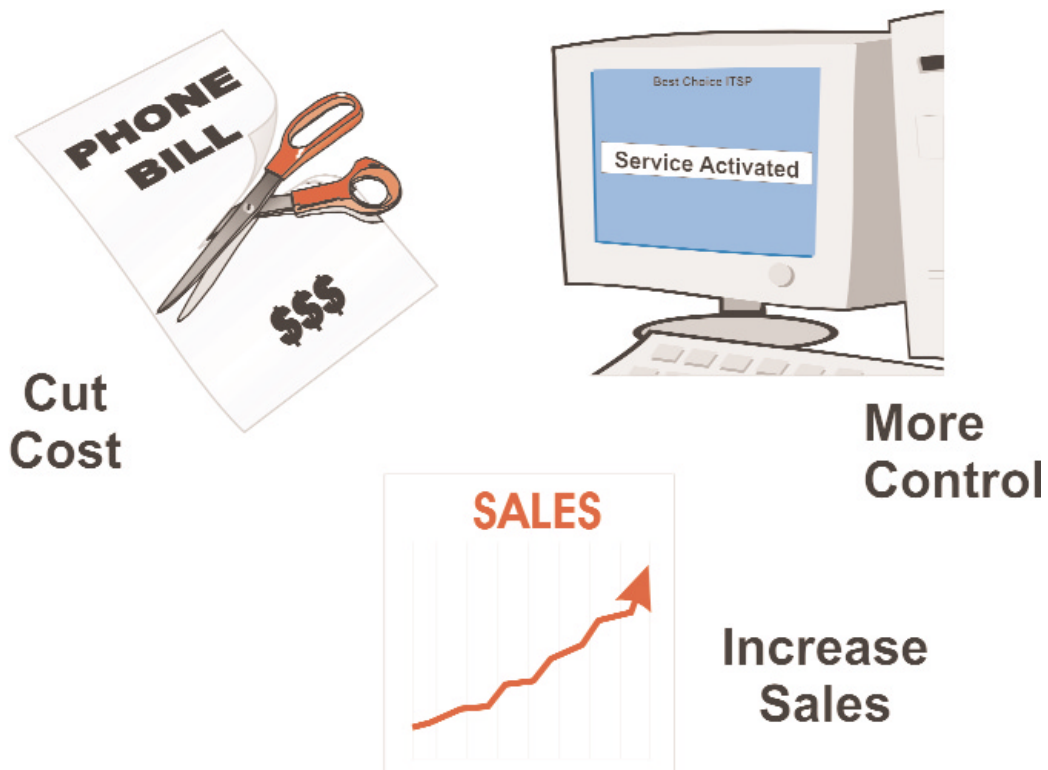

Figure 1., Why Companies are Converting to Voice Over Data Telephone Systems

## Introduction To IP Telephony

1. Much Lower Costs for the Same Service
2. Better Control of Communications Services
3. New Revenue Producing Services.

If your company already has a data communications system or high-speed Internet connections, it does not cost you much more to make calls through data networks to reach standard telephones. The cost for equivalent digital voice service through a data network is usually much less than 1 cent per minute and the cost for connection of digital voice calls to the public telephone network can be 1 to 3 cents per minute to almost anywhere in the world!

Most voice over data network systems allow you to directly control your service activation and feature controls through a standard internal or external web page. This means that you don't need to call a customer service representative (CSR) from the telephone company to setup or change your services. You or your staff can directly control over your own telephone services and features. In some cases, this control can be performed directly from an Internet web page.

Internet telephone service also can provide you with new revenue producing features and services. These features include the integration of marketing programs with telephone services, providing web pages that have audio links to customer service, and the use of multiple International telephone numbers that directly connect to your call centers at local calling rates.

## **Saving Money with Voice over Data Service**

Transferring your voice calls over data networks can save your company 70% or more compared to traditional telephone service (typically called "switched" telephone service). It is possible to use your existing telephone systems and methods of calling. It is possible to simply install some equipment that connects your existing PBX telephones to your data connection (such as a leased line or frame relay) using an audio adapter box. It is also possible to directly communicate with remote offices or customers if they

also use these multimedia adapters. These adapters produce a dialtone and allow callers to dial the same way that standard telephones or PBX telephones are dialed.

### **How Much Can My Company Save**

According to US department of commerce, corporations spend approximately 3% of gross sales on telecommunications costs. According to the federal communications commission (FCC), the average costs for telephone voice service in the United States in 2002 was:

- \$52.90 per month for business line connected to a PBX system
- 9 cents per minute domestic long distance
- 53 cents per minute for international calls

Source: "Universal Service Monitoring Report", October 2002, FCC pgs 576, 605

A telephone connection requires approximately 64 kbps of data transmission. Compared to the speed of company data networks, this is a relatively small amount of data transmission. The common data transfer rate for local area networks (LANs) is 100 Mbps (or more). This is almost 2000 times the speed of a typical telephone connection. Even wide area network (WAN) data connections (to connect offices to each other) used by companies typically range from 1 Mbps to 45 Mbps. The cost to send data as opposed to voice is approximately 10 to 20 times less.

Some data connections are temporary (called switched data) and other data connections are continuously connected (called dedicated). Switched data connections may charge by the minute or amount of data that is sent. Switched data connections allow for the rapid setup and disconnection of communication sessions. Dedicated connections usually charge a fixed monthly fee regardless of how much data is sent between two fixed points. Dedicated data connections usually have a lower cost per unit of data transferred compared to switch data connections.



## Introduction To IP Telephony

Figure 2 shows some sample comparisons between traditional charges for voice communication compared to the charges for sending data. This table shows that the average cost per minute for traditional telephone service (called switched voice) is approximately 4 cents per minute. If this service were to remain connected for 24 hours per day and 30 days in a month, this results in a monthly fee of \$1,728. A 56 kbps switched connection at 0.2 cents per minute results in a monthly charge of \$90. The approximate cost for fixed connections is \$50 per month for 56 kbps, \$500 per month for 1.5 Mbps (DS1), and \$50,000 per month for 45 Mbps connections (DS3). If you adjust the monthly fee for a 64 kbps voice data rate (64 kbps/data rate divided by 30 days x 24 hours x 60 minutes), the average cost of data connection that is used for voice is 4 cents for switched voice, 0.22 cents for switched data, 0.13 cents for fixed 56 kbps, 0.05 cents for fixed 1.5 Mbps, and 0.016 cents per minute for 45 Mbps.

	Switched Voice (63 Kbps)	Switched Data (56 Kbps)	Dedicated Data		
			(56 Kbps)	(1500 Kbps)	(4500 Kbps)
Cost per Month	<b>\$1728</b>	<b>\$90</b>	<b>\$50</b>	<b>\$500</b>	<b>\$5000</b>
Cost per Minute	<b>4 cents</b>	<b>0.20 cents</b>	<b>0.12 cents</b>	<b>1.12 cents</b>	<b>11.6 cents</b>
Cost per 64 Kbps	<b>4 cents</b>	<b>0.22 cents</b>	<b>0.13 cents</b>	<b>0.05 cents</b>	<b>0.01 cents</b>

Figure 2, Voice over Data and Telephone Service Cost Comparison

Another key reason why it may cost so little to use voice over data network service is may be able to use can use your existing data network (the data network and/or the Internet) without making many (if any) changes to it. Even if the person you want to call is not directly connected to your network, it is possible to use gateways to connect your voice over data call to the public telephone network. These gateways are located throughout the world at locations that are near the people you want to call. When you do call to the public telephone network, the additional cost of conversion from the data network to the public network is a small fraction of the cost (1 to 2 cents per minute) than if you dialed the call through the public telephone network.

## **How Can You Call Through Data Networks**

There are three basic ways that companies can use to call through data networks; call through a dedicated data line, call through a company's data network, and calling through the Internet.

### **Calling through a Dedicated Data Line**

If your company has a dedicated data communication line between offices, it is possible to install a voice gateway at each end so calls that are dialed between offices will go through the data line instead of through the public telephone network. When the voice gateway detects the calls are designated for the other company office (by analyzing the dialed digits), it can automatically switch the call to the data line.

If the capacity of the data line is significantly higher than the capacity required by voice communication, the voice traffic may be carried without having to increase the data transmission rate of the data line. This results in the voice communication between offices riding for free.

## Introduction To IP Telephony

Figure 3 shows how a company can insert a gateway at each office between the PBX system and the public telephone network to allow inter-office calls to go over the data connection. In this example, when a caller in the Los Angeles office dials another worker in the New York office, the call is automatically converted to data by the gateway in Los Angeles. The data call is then provided to a router in the existing data network where it is directed over the company's existing data connection. This example shows that if the data line becomes unavailable, the calls will then automatically be redirected through the public telephone network.

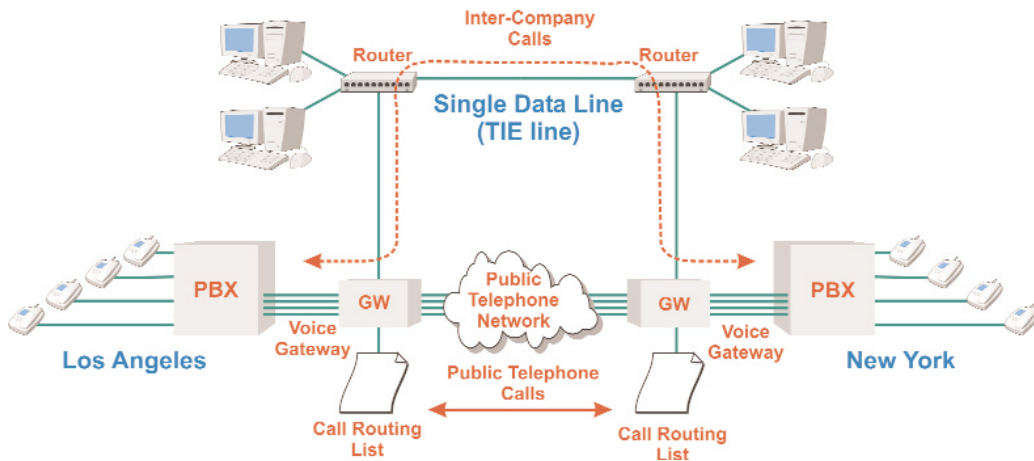

Figure 3, Calling Through a Data Line

## Calling through a Data Network

Calling through a data network (instead of only a single data line) involves managing multiple communication connection through the network. This involves adding a call server to the data network to manage the setup and connection of calls. The call server receives the dialed digits and determines the call processing required for the call to reach its destination. If the dialed number is within the company's communication system (within the company's data network), the call server can simply determine the network's data address that can connect the call. If the dialed number is outside the company's communication system (such as a public telephone), the call server will need to select a gateway device that can connect the call to the public telephone network.

Figure 4 shows how a company's data network has been modified to allow calls to pass through it. In this example, a call server in Chicago receives registrations and call requests from users connected to the company network in Chicago. When a caller dials the telephone number for a co-worker in the Atlanta office, the call request is first sent to the call server in Chicago. The call server uses the dialed digits to look up the data network address of the call recipient in Atlanta. The call server then and sends this destination network address back to the caller's IP telephone. The IP telephone can then directly communicate with the caller in Atlanta directly through the data network. If the caller in Chicago dials a number that is not on the company's network, the call server can instruct the IP telephone to use a voice gateway to allow the call to be completed through the public telephone network.

## Introduction To IP Telephony

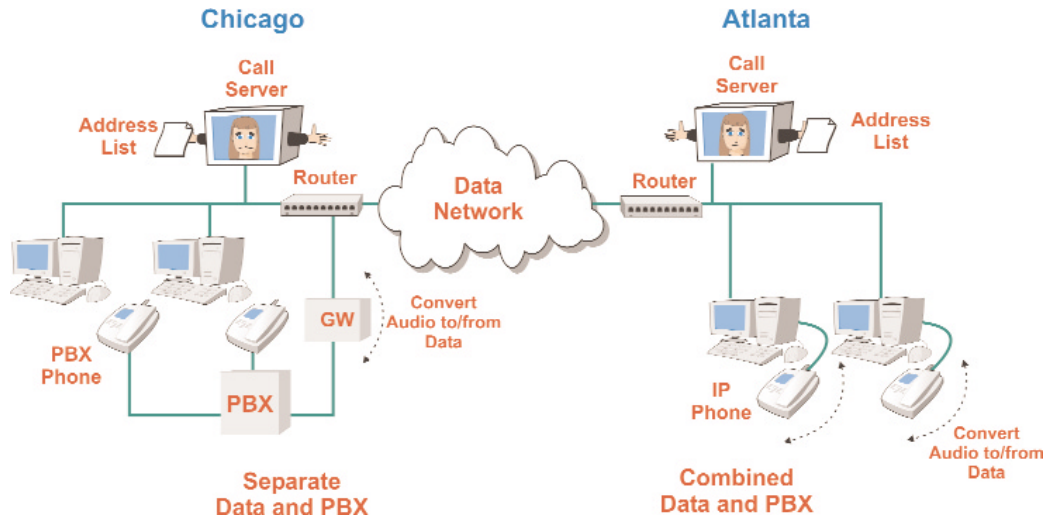

Figure 4, Calling Through a Data Network

## Calling Through the Internet

It is possible for companies to call directly through the Internet (instead of a company data network). Calling through the Internet does involve the management of connections between IP telephones and many voice gateways. To simplify calling through the Internet, it is possible to use IP Centrex or Internet telephone service providers (ITSPs). IP Centrex or ITSP companies can setup and manage multiple communication connections through data networks or through the Internet.

Figure 5 shows how calls can be made between company telephones through the Internet to standard telephones anywhere in the world. In this example, an existing company PBX telephone system in Paris is connected to the Internet through a voice gateway. Each PBX telephone is registered with a public Internet telephone service provider (ITSP) that is located in New York. The ITSP is able to provide connections to gateways located throughout the world. In this example, when the caller in Paris dials a telephone number in Cairo, the dialed digits are first routed to the ITSP in New York. The ITSP server searches for the telephone number in its address list. If it finds that it has access to a voice gateway (the ITSP may not actually own the voice gateway) that is connected to the Internet near the destination telephone number in Cairo, it informs the destination voice gateway that an incoming call is to be received. The ITSP then provides the PBX gateway with the data network address of the destination voice gateway in Cairo. The call can then proceed from the PBX telephone, through the PBX voice gateway, through the Internet, through the destination voice gateway (in Cairo), to the dialed telephone.

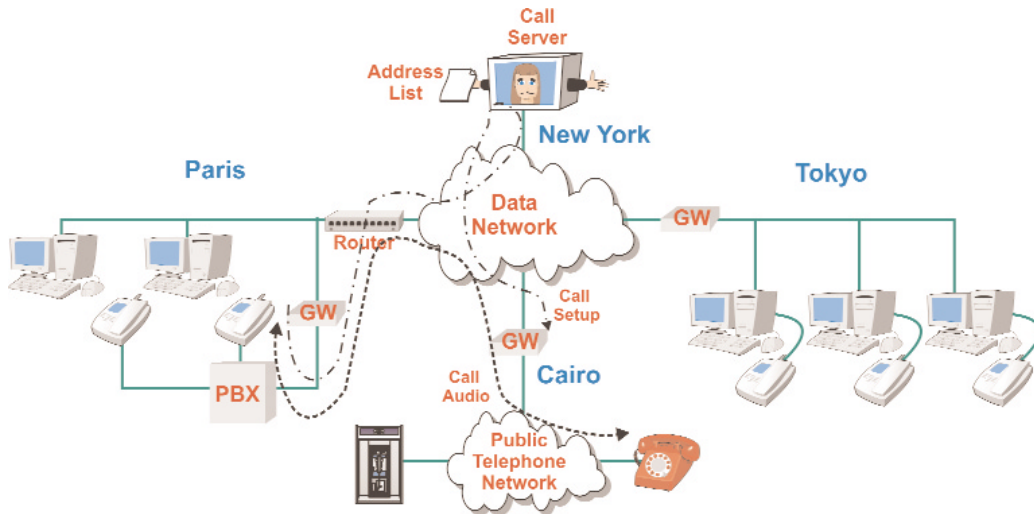

Figure 5, Calling Through the Internet

## Can I Still Use my Existing Systems Telephones

Yes, it is possible to use your existing telephones for voice over data network telephone service. Some data network adapters create a dialtone that allows standard telephone or PBX telephones to be used to make calls through the data network. This allows you to use standard analog telephones and telephone accessories such as answering machines, cordless telephones, and fax machines.

Figure 6 shows some of the different ways that a private telephone system (such as key systems and PBX systems) can send and receive voice calls over data networks. This diagram shows that one of the simplest ways (and often the first trials start this way) to upgrade the PBX system is to add an Internet telephone line using a standard telephone line adapter box. The next step is to start replacing the existing telephone lines with adapter

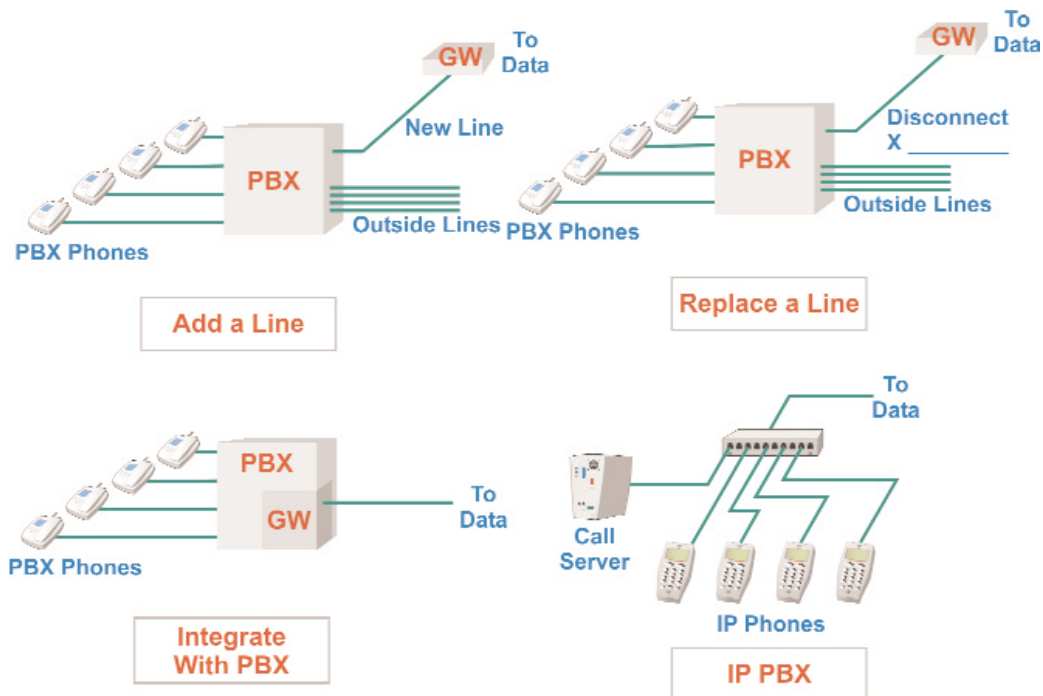

Figure 6, Using VoIP with Existing Telephone Systems

boxes. Next, the PBX system may be upgraded to allow direct connection to the data network (integration). Finally, some or all of the PBX system equipment may be replaced with a packet data switching system.

### **Does my Staff Have to Change How They Dial**

It is possible for your staff to call using voice over data network service and not change how they dial. Because the Internet does not know the physical location of your Internet telephone, it is usually necessary to dial the entire telephone number including the country code and area code (some places already require this).

There are other ways you can call other telephones and Internet telephones that may be less expensive. It is possible to direct connect through the Internet to other Internet telephones. The ways to direct connect include calling an Internet address, using the voice feature of Internet message services, using web pages, or even special email addresses for telephones. Using online telephone directories, it will even be possible to call a persons real name.

Figure 7 shows the different ways to call other standard telephones and Internet telephones through when using voice over data systems. The most basic way to dial is by using standard telephone numbers (via the keypad). The speed dial on this Internet telephone shows that it is also possible to call other telephones that are connected to a data network (such as an Internet telephone) by using web addresses, screen names, email addresses, and Internet addresses (IP addresses).



## Introduction To IP Telephony

### Dialing Options:

- Telephone Number
- Internet Address
- Web Address
- Email Address
- Other+++

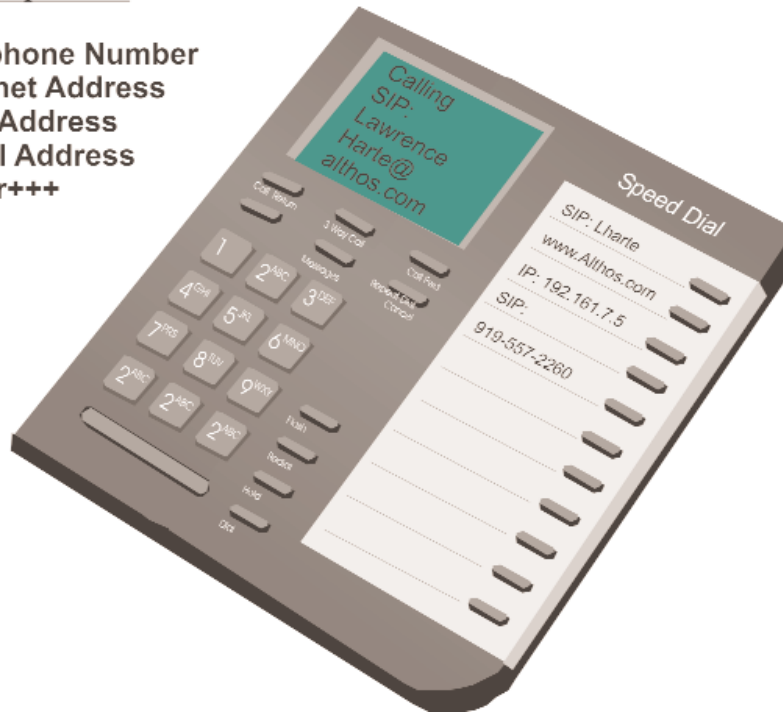

Figure 7, Dialing Options for Voice over Data Systems

### **Telephone Directories for Internet**

There are several places people can look to find your telephone number. Getting your number listed in directories so people can find you on the Internet may be different. If your IP Centrex and Internet telephone service providers (ITSPs) have assigned your IP telephone(s) a telephone number, they will usually have their own online directories. Some companies may be able to register you in the local telephone book of the city where your telephone number is assigned.

## **More Control over Your Telephone Services**

Voice over data network systems usually provide you with more direct control over your telephone services. Service is typically activated and changed directly through an internal web page. Instead of using a customer service representative (CSR) from the telephone company, you or your staff can setup the services directly. Your changes such as service activation can have immediate results.

### **Instant Activation**

Instant activation is the process of obtaining service immediately after applying for service. If you already have access to a data connection, service activation for services that use the data link for connections (such as Internet telephone service) can be instant.

Figure 8 shows how it is possible for a user or company system administrator to instantly activate a new voice over data telephone line. In this example, the system administrator has provided a list of user identification codes and passwords to allow new users to self activate themselves in the company's telephone network. After the user has entered the correct account identification codes, the user can setup their user details and their feature preferences (such as voice mail and call forwarding options).

## Introduction To IP Telephony

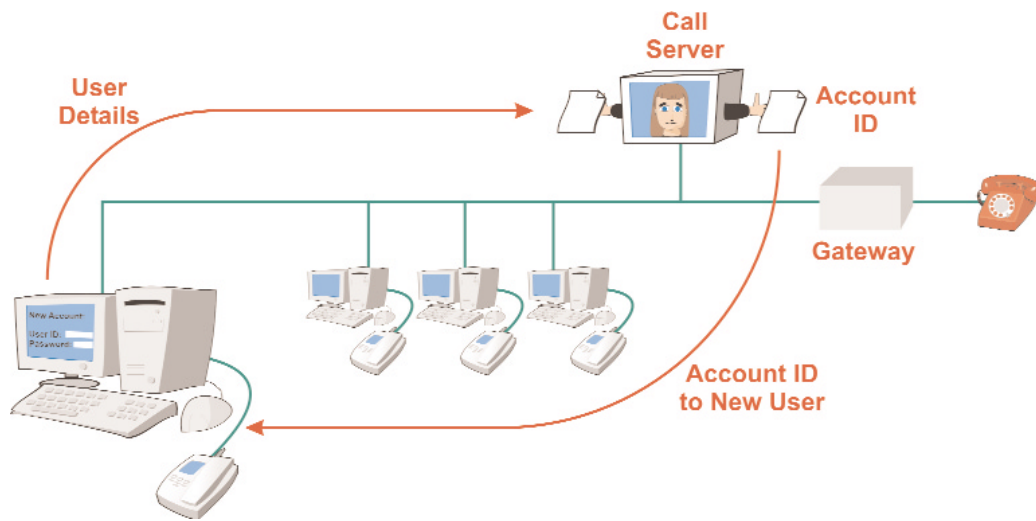

Figure 8, VoIP Instant Line Activation

## Real Time Accounting and Billing

Real time accounting and billing is the process of gathering, rating, and displaying (posting) of account information either at the time of service request or within a short time afterwards (may be several minutes). Voice over data telephone service commonly allows for real time billing for tracking of voice over data telephone calls.

Figure 9 shows how voice over data service can provide real time accounting and billing records immediately after they are created (in real time). This example shows how the call server keeps track of each call as it processes each call setup. It uses the call setup and termination information to adjust the accounting and billing information. In this example, these charges or usage amounts can be displayed immediately through an Internet web page.

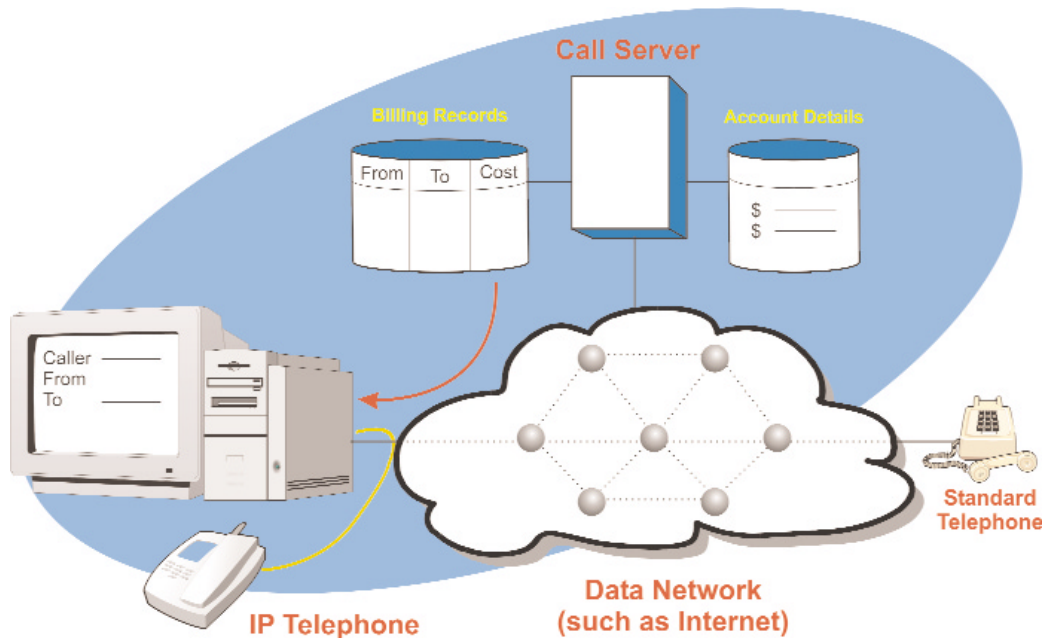

Figure 9, Voice over Data Real Time Accounting and Billing

## New Revenue Producing Features and Services

Internet telephone provides for advanced features and service that are not possible with traditional telephone service. These advanced features include sophisticated call routing control, unified messaging, and multimedia transmission.

## Integrated Sales Information and Telephone Systems

It is possible to link voice over data network telephone systems with existing information systems. Using the telephone number or other identifying

## Introduction To IP Telephony

information, information can be gathered about callers and this can be provided to customer service representative via a “screen pop.”

Figure 10 shows that because VoIP telephone systems can share the same type of data network, the telephone system can be more easily integrated with the company’s information system. In this example, a customer service representative (CSR) is receiving a call from John Doe. The screen pop shows that John Doe has already purchased a book. The CSR can use the account information from John Doe to help him find additional products to purchase.



### **Customer Service Representative (CSR)**

Figure 10, Integrated Sales and Telephone Systems

### **Increased Geographic Market Using Local Telephone Numbers Throughout the World**

Companies can connect voice over data networks to telephone systems located throughout the world to increase their market presence. Using telephone numbers located throughout multiple cities allows callers to dial local tele-

phone numbers and calls can be connected to your company through the data network or the Internet at very low cost.

Figure 11 shows how a person or company can get a telephone number in another country. In this example, a person in Paris gets a telephone number in New York City (area code 212). When a local caller dials the Internet telephone number, the call is connected to the Internet telephone that is located in Paris. The caller in New York City is paying for a local call and the connection between New York City and the Internet telephone in Paris is free.

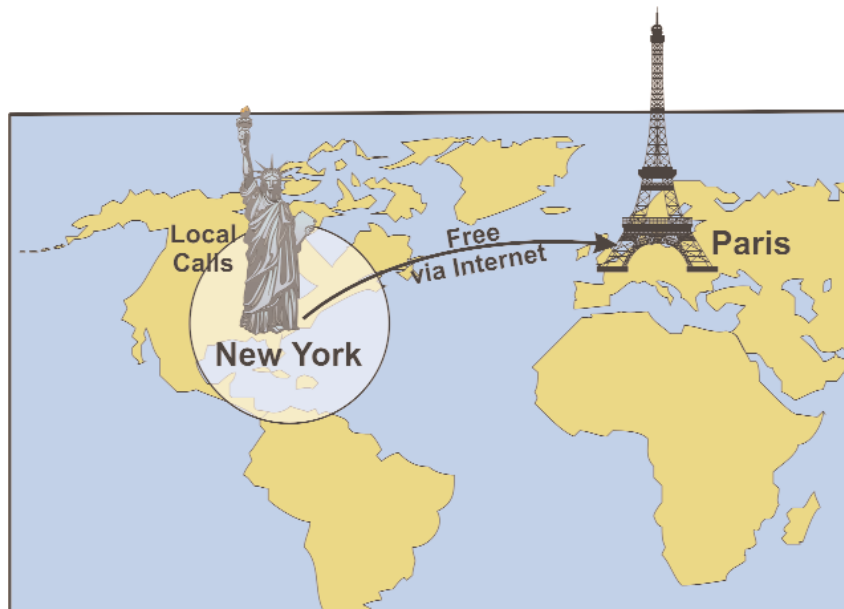

Figure 11, Increased Geographic Market Potential

### **Call Routing Control (Intelligent Call Forwarding)**

Intelligent call forwarding changes the route of incoming calls to alternative destinations based on your preferred settings and the status of a telephone line or communication session when an incoming call is received.

## Introduction To IP Telephony

Some of the advanced control features include transferring calls based on the time of day, amount of time an unanswered line is allow to ring before transfer (such as transfer to voice mail), or to transfer the call to another number where you last made a call (call following). Using intelligent call forwarding, you can setup your own hunt group (call rollover) anytime you want. The setup of intelligent call forwarding is usually accomplished via an Internet web page.

Figure 12 shows an example of intelligent call forwarding that allows the destination of the call forwarding number to be changed based on time of day and location of the caller. In this example, these changes are made via web pages. This diagram shows that the user has setup intelligent call forwarding via a web page that changes the call forwarding number to an office number during normal working hours. When the call is received out of these hours, it is routed to a home office telephone.

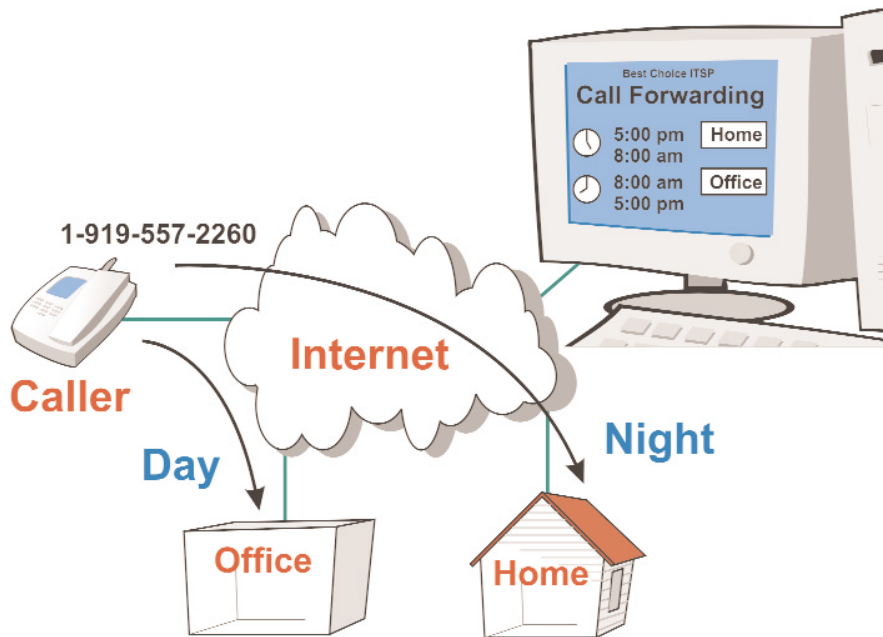

Figure 12, Intelligent Call Forwarding

## Remote Multimedia Communication

Multimedia is a term that is used to describe the delivery of different types of information such as voice, data or video. Because Internet telephone service is often used with broadband (high-speed) data services, it is possible to send multiple types of information at the same time.

Figure 13 shows how a company can use remote multimedia to provide for corporate training or to conduct fully interactive inter-company meetings linking different people at different locations. This diagram shows that multiple forms of media can be sent during a voice over data network telephone call. This example shows a single broadband connection can simultaneously allow telephone calls (voice over data Telephone service), transfer data (such as a PowerPoint presentation), and allow the display of video (such as video images of the presenter). In this scenario, a team leader in New York is presenting a new product to employees in Paris and London. Each participant can see the team leader on his or her monitor in a window box and hear the presenter on their voice over data telephone (using speakerphone). They can also see the course presentation on another window in the computer monitor along with hearing the professor by the audio on the computer speakers or telephone.

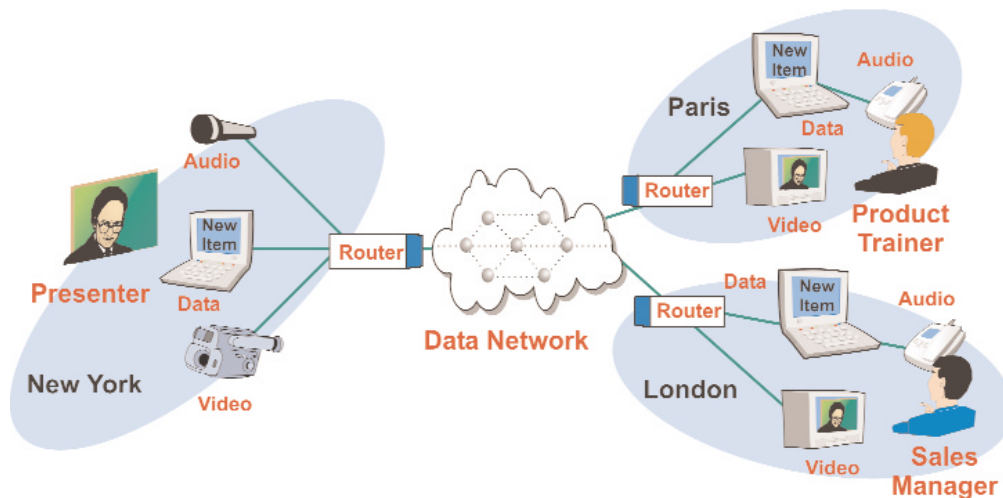

Figure 13, Remote Multimedia Communication



## **How Voice over Data and Internet Telephone Systems Work**

Understanding the basics of how Voice over Data and Internet telephone service works will help you make better choices and may help you to solve problems that can be caused by selecting the wrong types of equipment and services.

### **Technology Knowledge –Helping to Make The Right Choice**

Voice over Data Network and Internet telephone service operates by converting voice signals to data packets, sending these data packets through the Internet, converting these packets back into telephone like signals, and managing the overall call setup (dialing), connection, and termination (hang-up).

### **Converting Voice to Data**

A key first step in providing Internet telephone service is converting the analog audio voice signal into a digital form (digitize it) and then compressing the digitized information into a more efficient form.

## **Digitization – Why and How**

Digitization is performed because digital information can provide for better voice quality and digital signals are easier to work with than their analog counterparts.

Digitization is the conversion of analog signals (continually varying signals) into digital form (signals that have only two levels). To convert analog signals to digital form, the analog signal is sampled and digitized by using an analog-to-digital (pronounced A to D) converter. The A/D converter periodically senses (samples) the level of the analog signal and creates a binary number or series of digital pulses that represent the level of the signal.

Analog signals are converted into digital signals because they are more resistant to noise (distortion) and they are easier to manipulate than analog signals. For the older analog systems (continuously varying signals), it is not easy (and sometimes not possible) to separate the noise from the analog signals. Because digital signals can only have two levels, the signal can be regenerated and during this regeneration process, the noise is removed.

Figure 14 shows the basic audio digitization process. This diagram shows that a person creates sound pressure waves when they talk. These sound pressure waves are converted to electrical signals by a microphone. When the microphone senses a large sound pressure wave (loud audio), it produces a large (higher voltage) analog signal. To convert the analog signal to digital form, the analog signal is periodically sampled and converted to a number of pulses. The larger the analog signal is, the larger the number of pulses that are produced. The number of pulses can be counted and sent as digital numbers. This example also shows that when the digital information is transmitted, it may acquire distortion during transmission. A digital receiv-

## Introduction To IP Telephony

er that detects the high or low signal levels and uses these levels to recreate new digital signals can eliminate this distortion. This conversion process is called regeneration or repeating. This regeneration process allows digital signals to be sent at great distances without losing the quality of the audio sound.

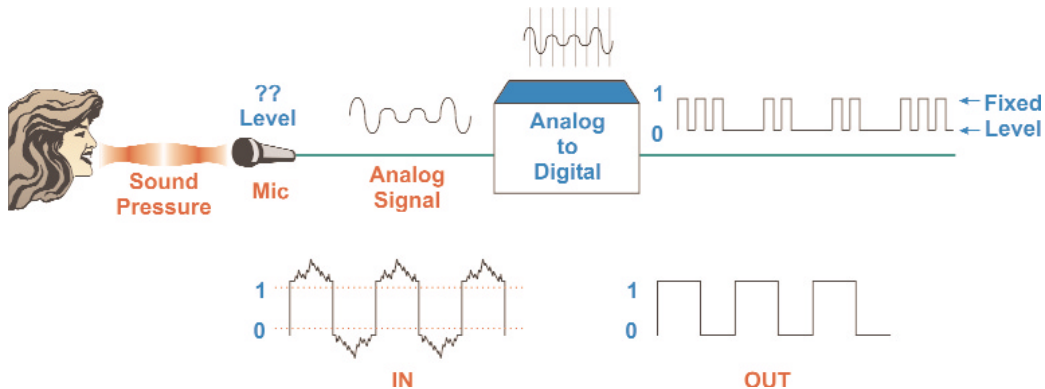

Figure 14, Audio Digitization

## Digital Speech Compression – Gaining Efficiency

Digital speech compression is a process of analyzing a digital speech signal (digitized audio) and using the analysis information to convert the high-speed digital signals that represent the actual signal shape into lower-speed digital signals that represent the actual content (such as human voice). This

process allows Internet telephone service to have lower data transmission rates than standard telephone service while providing for good quality audio.

Figure 15 shows the basic digital speech compression process. In this example, the word “HELLO” is digitized. The initial digitized bits represent every specific shape of the digitized word HELLO. This digital information is analyzed and it is determined that this entire word can be represented by three sounds: “HeH” + “LeL” + “OH.” Each of these sounds only requires a few digital bits instead of the many bits required to recreate the entire analog waveform.

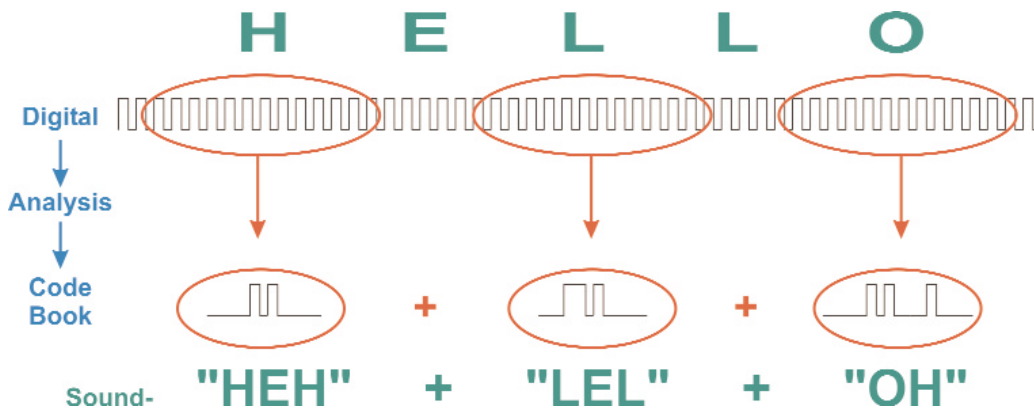

Figure 15, Digital Speech Compression

## **Sending Packets**

Sending packets through the Internet involves routing them through the network and managing the loss of packets when they can't reach their destination.

### **Packet Routing Methods**

Packet routing involves the transmission of packets through intelligent switches (called routers) that analyze the destination address of the packet and determine a path that will help the packet travel towards its destination.

Routers learn from each other about the best routes for them to select when forwarding packets towards their destination (usually paths to other routers). Routers regularly broadcast their connection information to nearby routers and they listen for connection information from connected routers. From this information, routers build information tables (called routing tables) that help them to determine the best path for them to forward each packet to.

Routers may forward packets towards their destination simply based on their destination address or they may look at some descriptive information about the packet. This descriptive information may include special handling instructions (called a label or tag) or priority status (such as high priority for real time voice or video signals).

Figure 16 shows how blocks of data are divided into small packet sizes that can be sent through the Internet. After the data is divided into packets (envelopes shown in this example), a destination address along with some description about the contents is added to each packet (called in the packet header). As the packet enters into the Internet (routing boxes shown in this diagram), each router reviews the destination address in its routing table and determines which paths it can send the packet to so it will move further towards its destination. If a current path is busy or unavailable (such as

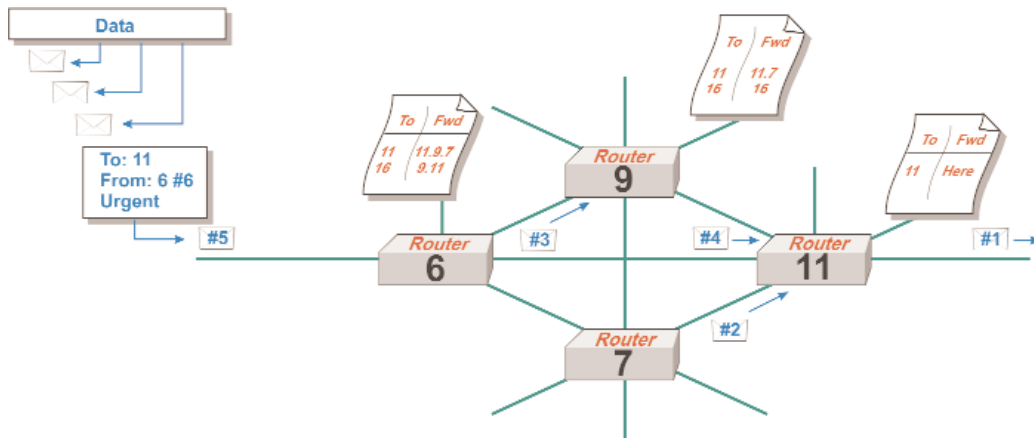

Figure 16, Packet Transmission

shown for packet #3), the router can forward the packets to other routers that can forward the packet towards its destination. This example shows that because some packets will travel through different paths, packets may arrive out of sequence at their destination. When the packets arrive at their destination, they can be reassembled into proper order using the packet sequence number.

### Packet Losses and Effects on Voice Quality

Packet losses are the incomplete reception or intentional discarding of packets of data as they are sent through a network. Packets may be lost due to broken line connections, distortion from electrical noise (e.g. lightning spike), or through intentional discarding due to congested switch conditions. Packet losses are usually measured by counting the number of data packets that have been lost in transmission compared to the total number of packets that have been transmitted.

## Introduction To IP Telephony

Figure 17 shows how some packets may be lost during transmission through a communications system. This example shows that several packets enter into the Internet. The packets are forwarded toward their destination as usual. Unfortunately, a lightning strike corrupts (distorts) packet 8 and it cannot be forwarded. Packet 6 is lost (discarded) when a router has exceeded its capacity to forward packets because too many were arriving at the same time. This diagram shows that the packets are serialized to allow them to be placed in correct order at the receiving end. When the receiving end determines a packet is missing in the sequence, it can request that another packet be retransmitted. If the time delivery of packets is critical (such as for packetized voice), it is common that packet retransmission requests are not performed and the lost packets simply result in distortion of the received information (such as poor audio quality).

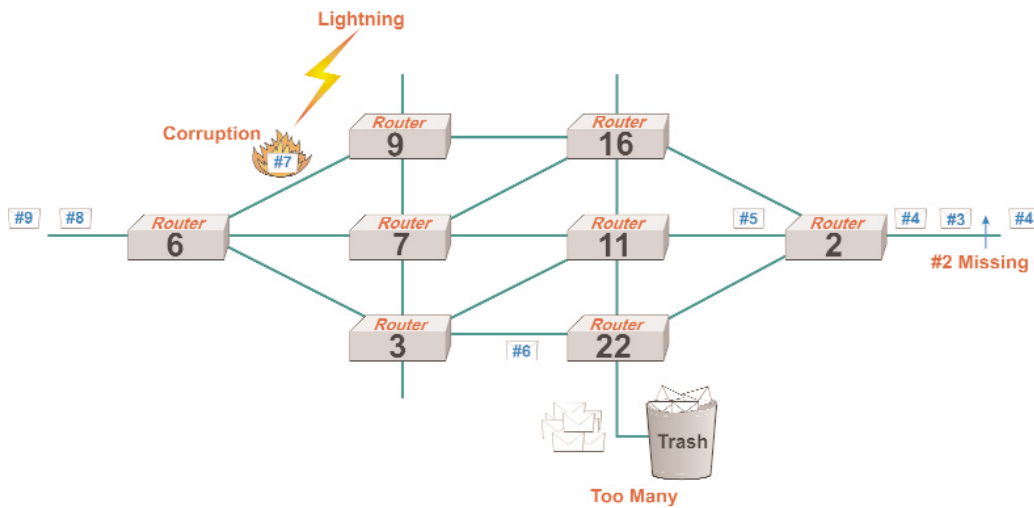

Figure 17, Packet Losses

## **Converting Packets to Telephone Service**

IP telephone data packets are converted back to telephone signals via gateways. Gateways may interconnect IP telephone service to the public telephone network or they may simply convert to another format such as a private telephone system (e.g. PBX).

## **Gateways Connect the Internet to Standard Telephones**

A voice gateway is a communications device or assembly that transforms audio that is received from a telephone device or telecommunications system (e.g. PBX) into a format that can be used by a different network. A voice gateway usually has more intelligence (processing function) than a bridge as it can select the voice compression coder and adjust the protocols and timing between two dissimilar computer systems or voice over data networks.

Figure 18 shows how a gateway connects a telephone device to the data network (such as the Internet). This example shows that the gateway must convert both audio and control signals. There are two audio paths through the gateway, one from the caller to the Internet and the other from the Internet to the caller. The gateway converts the audio from the telephone set microphone to packets of data that can be sent through the Internet on channel 1. Packets that are received from the Internet are converted to audio on channel 2. The gateway also monitors for control commands to be received from the telephone or the Internet. This example shows that the user has requested to make a three way call by pushing the flash button on the telephone (or by momentarily pressing the hook-switch). The gateway senses this request and creates a control packet that is sent to the ITSP. When the ITSP receives this request, it sends a command message to the gateway indicating it should create a dialtone and gathers the dialed digits for the three-way call.



Introduction To IP Telephony

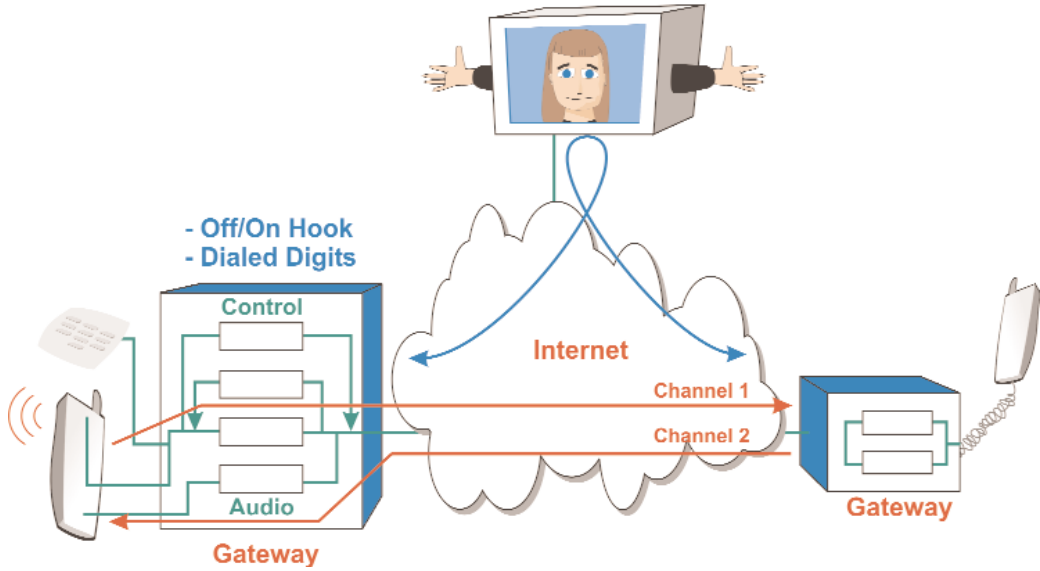

Figure 18, Audio Gateways

### Managing the Connections

Gatekeepers control the setup, connection, feature operation, and disconnection of calls through the data network. Gatekeepers can be owned and operated by private companies, or public service providers such as Internet telephone service provider (ITSP).

## **Gatekeepers Control the Calls**

Gatekeepers are computers that maintain lists of the IP addresses of customers and gateways, process requests for calls and features, and coordinate with the gateways that convert IP telephone calls to standard telephone calls. Gatekeepers perform access control, address translation, services coordination, control signaling coordination, and bill record recording.

Figure 19 shows how a gatekeeper sets up connections between IP telephones (Internet telephones in this example) and telephone gateways. The gatekeeper receives registration messages from an Internet telephone when it is first connected to the Internet. This registration message indicates the current Internet address (IP address) of the Internet telephone. When the Internet telephone desires to make a call, it sends a message to the ITSP that includes the destination telephone number it wants to talk to. The ITSP reviews the destination telephone number with a list of authorized gateways. This list identifies to the ITSP one or more gateways that are located near the destination number and that can deliver the call. The ITSP sends a setup message to the gateway that includes the destination telephone number, the parameters of the call (bandwidth and type of speech compression), along with the current Internet address of the calling Internet telephone. The gatekeeper then sends the address of the destination gateway to the calling Internet telephone. The Internet telephone then can send packets directly to the gateway and the gateway initiates a local call to the destination telephone. If the destination telephone answers, two audio paths between the gateway and the Internet telephone are created. One for each direction and the call operates as a telephone call.

Introduction To IP Telephony

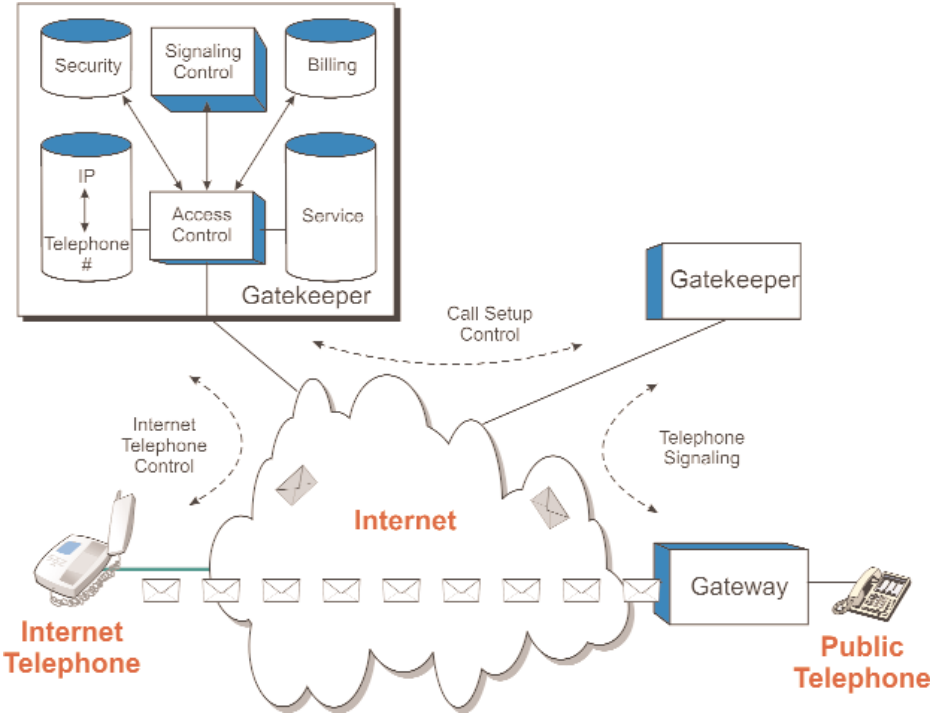

Figure 19, Gatekeepers

## **IP Communication Systems - Control of Service Access, Features and Billing**

There are three basic types of systems that are used to provide IP telephony service for businesses; Internet telephony service provider (ITSP), IP Centrex, and Internet protocol private branch exchange (iPBX).

### **Internet Telephony Service Providers (ITSPs)**

Internet telephony service providers (ITSPs) supply public IP telephone services to their customers that are connected to the Internet. ITSPs usually allow the customer to interconnect their telephones to public telephones for a usage fee. ITSPs control the customers' access to services and features through the use of gatekeepers (also known as call servers) and gateways (that it may or may not own), and computers that perform billing and customer care operations.

Customers use IP telephone access devices (sometimes called terminals) or IP telephone adapters to communicate their requests for services and features to the ITSP. The ITSP receives their requests and determines what features they are authorized to access. If the ITSP decides to provide service, it will determine the gateway that can be used to complete the call to the destination number (if the call is going off-the-net). The gateway will record the time and usage information and send it to the ITSP to account for the usage (to get paid). Because there are many gateways throughout the world, gateways are commonly connected to clearinghouse companies to settle the usage charges. These clearinghouses gather all the billing details (may be hundreds of thousands of billing records per month) for each ITSPs who has used the gateway and create invoices for each ITSP periodically.

## Introduction To IP Telephony

Figure 20 shows that ITSPs are primarily made of computers that are connected to the Internet and software to operate call processing and other services. In this diagram, a computer keeps track of which customers are active (registration) and what features and services are authorized. When call requests are processed, the ITSP sends messages to gateways via the Internet allowing calls to be completed to telephones that are connected to the public telephone network. These gateways transfer their billing details to a clearinghouse so the ITSP can pay for the gateway's usage. The ITSP then can use this billing information to charge the customer for calls.

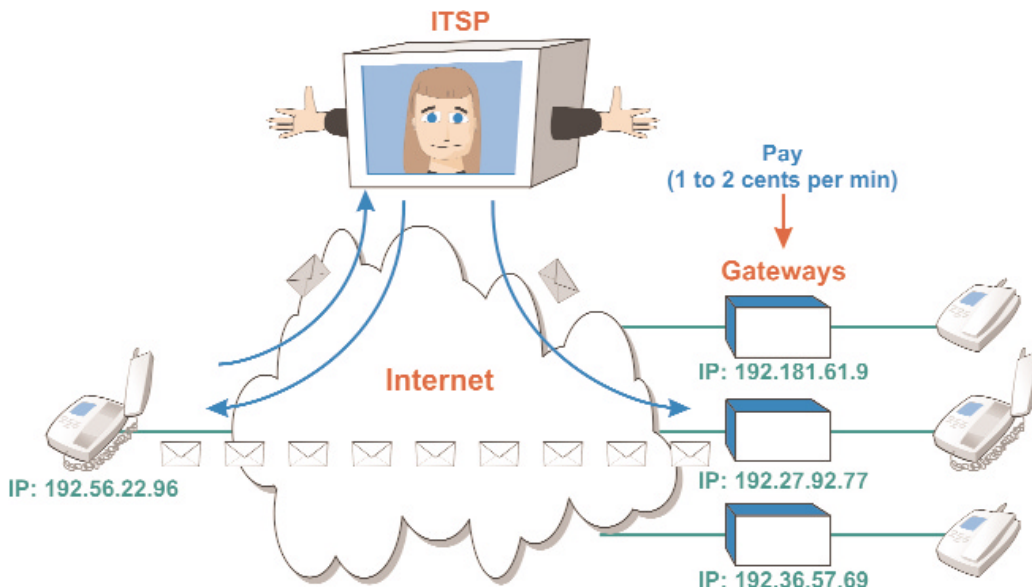

Figure 20, Internet Telephony Service Provider Operation

## **Internet Protocol Centrex (IP Centrex)**

IP Centrex is a system that provides Centrex call processing services to customers via Internet protocol (IP) connections. IP Centrex allows customer to have and use features that are typically associated with a private branch exchange (PBX) without the purchase of PBX switching system equipment. These features typically include 3 or 4 digit dialing, intercom features, distinctive line ringing for inside and outside lines, voice mail waiting indication and others.

IP Centrex systems are primarily made of IP telephones that are owned or leased by the end-user company and gateways and call servers that are owned and controlled by the IP Centrex operator.

The end-user company is usually given access to the Centrex system for administrator control and user control (possibly a web page). The administrator control allows the system administrator of the end-user company to setup and remove new user accounts (extensions) along with the management of authorized telephone features for each account. The user's control panel allows the end-user to setup their preferences for features such as call forwarding or voice mail operation. The IP Centrex service provider uses this information to control and coordinate the end-user's access to services and features.

Figure 21 shows a simplified IP Centrex system that provides telephone services to IP telephones that are connected to a company's local area data network. This diagram shows that the IP Centrex telephone system consists of IP telephones located at the customers location, a data connection that can connect the IP telephones to the IP Centrex system, a Centrex call processing system (call server), and gateways that allow the IP Centrex service provider to interconnect calls to the public telephone network. Each IP telephone has its own network data address and it registers with the IP Centrex call server when it is connected to the company's data network. When calls are received from the PSTN at the IP Centrex system, the call server looks in it's databases to find the associated IP telephone address (data address) and this address is used to alert the IP telephone of an incoming call. When

## Introduction To IP Telephony

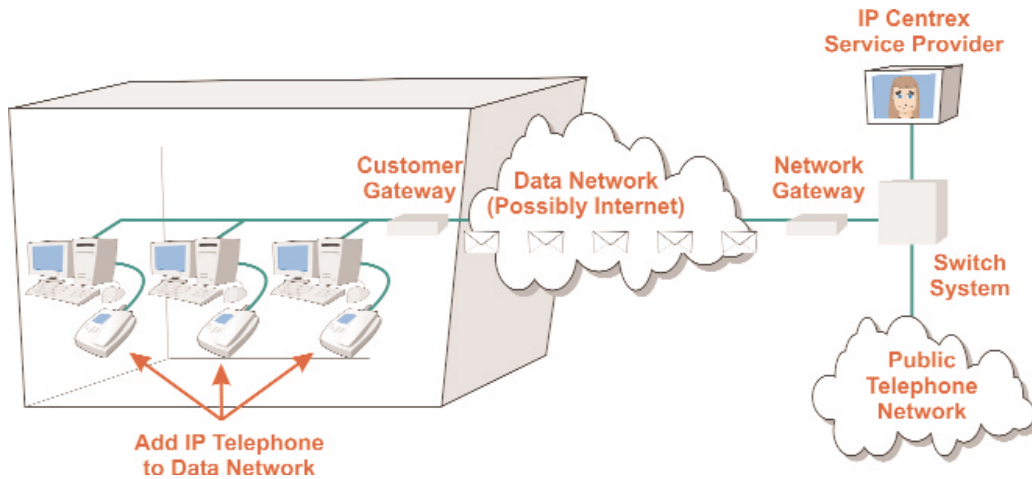

Figure 21, IP Centrex Operation

calls are originated from the IP telephone, the dialed telephone number is passed to the IP Centrex call processing system. This system determines if the call is routed within the data network (an internal calls) or if the voice gateway must be used to connect the call to the PSTN.

## Internet Protocol Private Branch Exchange (iPBX)

Internet protocol private branch exchange (IPBX) systems use standard Internet protocols to provide voice communications for companies. IPBX systems can be a separate system from data network or they may share the data network systems. When the iPBX system shares the local area network (LAN), it may be called LAN Telephony or TeLANophy.

IPBX systems use a IP telephone server (call server) to provide for call processing functions and to control gateways access that allows the IPBX to communicate with the public switched telephone network and other IPBX's

that are part of its network. IPBX systems can provide advanced call processing features such as speed dialing, call transfer, and voice mail along with integrating computer telephony applications.

IPBX systems are primarily made of IP telephones, call servers, and gateways that are owned and controlled by the company that uses the system. The software installed on the iPBX system allows a system administrator (possibly by a dedicated terminal or an internal web page) to setup and remove new user accounts along with a list of authorized features.

The call server coordinates the addresses that the IP telephones use to communicate with other devices. This allows the call server to instruct the IP telephone to talk to another IP telephone within the system (internal calls) or to the public telephone network through voice gateways.

There may be several different voice gateways that the iPBX system may use to connect to the public telephone network. Usually, there is a voice gateway that can connect the iPBX system to the local public telephone network. The iPBX system may also communicate with other gateways that are located throughout the world so long distance calls can be routed through low costs data networks (such as the Internet). When the voice over data call reaches its destination gateway, it is converted back telephone signals. For example, if an end-user in New York dials a phone number in Berlin and the iPBX system has access to a gateway in Berlin, it will assign the IP telephone to communicate with the voice gateway address in Berlin. This will allow this international call to become a local call in Berlin.

Figure 22 shows an iPBX system that shares a company's local area data network. This diagram shows that an iPBX telephone system consists of IP telephones, a data network, a call processing system, and a voice gateway to the public telephone network. IP telephones convert audio into digitized packets that are transferred on the call server. Each IP telephone has its own network data address. The call server communicates with IP telephones over the same high-speed LAN data network that communicates with computers. When calls are received from the PSTN, the call processing system looks in the database to find the associated IP telephone address (data address) and this address is used to alert the IP telephone of an incoming call. When calls are originated from the IP telephone, the dialed tele-



## Introduction To IP Telephony

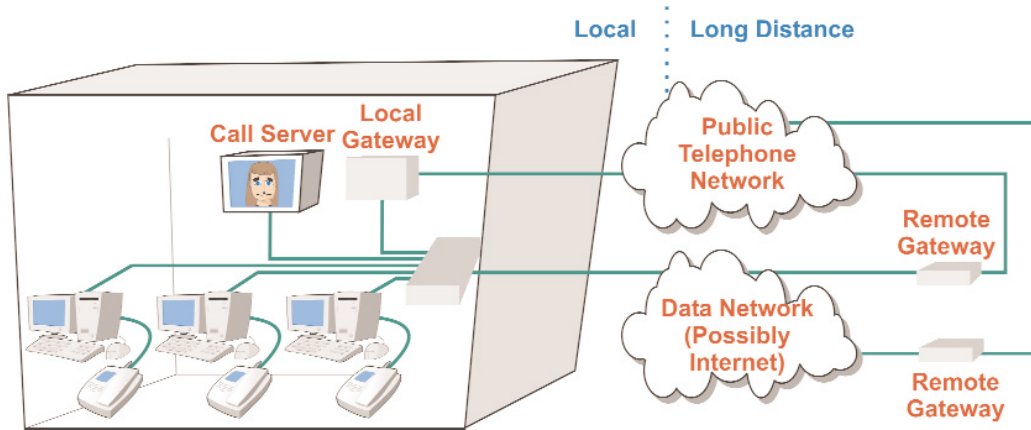

Figure 22, Internet Protocol Private Branch Exchange (iPBX) Operation

phone number is passed to the call processing system (call server). This system determines if the call is routed within the data network or if the voice gateway must be used to connect the call to the PSTN. This diagram also shows that the iPBX system can route a call through a data network (such as the Internet) to a distant voice gateway to allow for low cost connection to the public telephone networks at distant locations.

## Voice Over Data (VoIP) Networks

Voice over data networks is primarily constructed of computer servers and gateways. Servers control the overall system access and processing of calls and gateways convert the voice over data network data to signals that can be used by telephone access devices.

Figure 23 shows the basic network parts of VoIP networks and how they may be interconnected through private or public (e.g. Internet) data net-

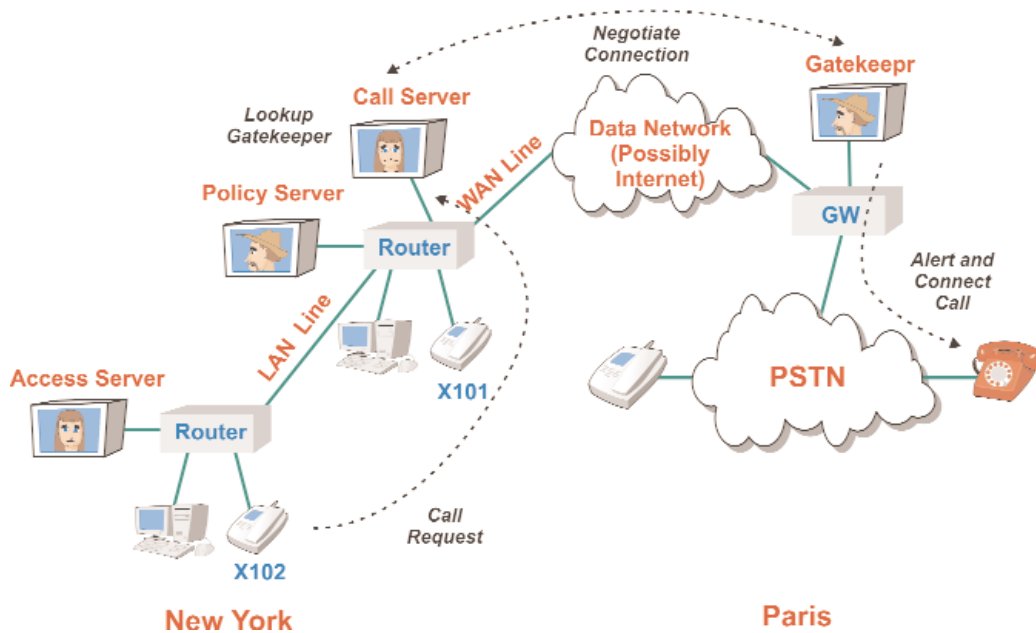

Figure 23, Voice over Data Network Server Operation

## Introduction To IP Telephony

works and some of the common servers that are used to manage the connections and features for IP telephones. In this example, an iPBX telephone at x102 dials a public telephone in Paris through the company's LAN system. When the PBX telephone is first connected to the data network, it registers with the registrar (access) server. The access server provides the IP telephone with access to the data network (such as the Internet) by assigning it an Internet address. When the user dials the telephone number for the phone in Paris, the iPBX telephone sends a call request message to the call server. The call server reviews its lists of gatekeepers (other servers) and determines the best choice for connecting the call. The call server then contacts the gatekeeper through the wide area network (WAN) connection and negotiates for a connection (bandwidth and features). A policy server has been programmed to give priority access voice communications on the WAN network connection to help ensure the call quality is acceptable. The gatekeeper then commands its gateway to alert (ring) the telephone in Paris. If the recipient in Paris answers the phone, the call can be connected from extension 102, through the LAN, through the WAN, through the gateway, through the telephone network in Paris, to the telephone in Paris.

A key consideration in converting to voice over data telephone service is the assignment or reuse of existing telephone numbers. The ability to keep your existing telephone numbers is called telephone number portability. The key types of number portability include local, geographic, and service number portability.

## Servers

Servers are computers or data processing devices that manage the setup or connection of calls. There can be many types of servers within a voice over data network. Server functions can be divided into functional parts such as access control, call management (call servers), network provisioning, billing, and other servers that are used for the support of communication services. Call servers that setup and manage calls are commonly called call managers or gatekeepers.

## **Proxy Servers**

Proxy servers are interfaces between data processing devices (e.g. computers or IP telephones) that are connected to a local network and an external network (e.g. the Internet). A proxy server has two network interfaces. One interface communicates with the local area network (e.g. Ethernet) and the other network interface (e.g. DSL modem) communicates with another data network.

Proxy servers act on behalf of the telephone device to redirect call requests to other addresses. Locations. A proxy server can simply redirect the request to the latest address where the designated recipient has been registered or it may process the call request to send out multiple call request messages (called a forking proxy). A forking proxy forwards a communication session request to more than one device on behalf of the communication connection request. These messages may be sent out sequentially (trying more likely locations first) or they may be sent out simultaneously (to ring multiple extensions at the same time).

## **Remote Access Dial In User Server (RADIUS)**

RADIUS servers are network devices that receive identification information from a potential users of network services, authenticate the identity of each user, and validates the authorization to use the requested service and creates event information for accounting purposes.

## **Registrar Servers (RAS)**

A registrar server maintains information regarding the location of resources that are located within a network (such as the Internet). Registrar servers (also called Location servers) are part of the telephony routing over Internet protocol (TRIP) system that permit telephone devices to discover and register with their servers or gatekeepers. Location servers regularly exchange information with each other.

## **Provisioning Servers**

Provisioning servers coordinate the activation setup, authorization of features, and elimination of users from a communications system.

## **Call Detail Record (CDR) Servers**

Call detail record (CDR) servers collect and process call usage information for the creation of call accounting and billing information.

## **Policy Server**

Policy servers coordinate the allocation of network resources based on pre-determined policies on the priorities and resources required by communication services and applications within the network. A policy server is used to help manage network and prioritize operation in the event of loss of resources. The pre-set policies define which communication services are critical (such as voice) and how much resources should be allocated to these critical services at the expense of other communication services (such as web browsing).

## **Domain Name Server (DNS)**

Domain name servers (DNS) translate text and numeric names to network addresses such as a DNS that converts web addresses into IP addresses. A DNS uses a distributed database containing addresses of other DNS servers that may contain addresses it does not have within its own database.

## **Gateways**

Gateways are communications devices or assemblies that transform data that is received from one network into a format that can be used by a dif-

ferent network. Gateways used for voice over data networks convert voice signals to and from data packets. These gateways may also adjust the protocols and timing between two dissimilar computer systems or data networks. Gateways can be origination (converting from voice to packets) or termination gateways (from packets to voice).

Gateways may be audio (voice) gateways or signaling (control) gateways. Audio gateways convert VoIP data packets to audio signals. Signaling gateways convert control messages between VoIP systems and other systems (such as the public telephone network).

### **Audio Gateways**

Audio gateways can be in the form of network gateways, terminal adapters, or integrated access devices (IADs). Network gateways convert VoIP data packets into telephone signals that are transferred to telephone lines such as multichannel T1, E1 lines. Terminal adapters convert VoIP data packets into signals that can be used by other types of telephone devices (such as analog telephones). Integrated access devices combine telephone set with an audio gateway (e.g. IP telephones).

### **Signaling Gateways (SG)**

A signaling gateway (SG) is used to interface a signaling control system (e.g. such as SIP or H.323) to other types of network devices (such as the signaling system used on the public telephone network). Signaling gateways convert message formats, translate addresses, and allow different signaling protocols to interact.

### **Network Capacity**

When voice systems are integrated with data networks, the network capacity is shared between voice and data systems. The network capacity sharing

## Introduction To IP Telephony

issues include LAN network capacity and wide area network interconnection capacity.

Each voice communication session for voice over data systems requires between 14 kbps to 90 kbps of data transmission bandwidth. The amount of bandwidth that each voice communications session requires varies based on the quality of service (QoS) desired and the type of data compression (speech compression) that is used. Because it is possible for the network operator to select the amount of data compression, this allows the network capacity to vary (called Soft capacity) as it is possible for more users can talk using the same amount of bandwidth by reducing the audio quality.

The sharing of bandwidth can be managed through the use of protocols (such as reservation protocols) or it can be left to the network to automatically decide how to allocate bandwidth. For high-speed data networks such as LAN systems, the amount of available bandwidth is usually thousands of times higher than the bandwidth required by each IP telephone. As a result of this, the priority control processes designed into the standard data routers may be sufficient to provide for high QoS within the LAN system. For wide area networks that have more limited interconnection bandwidth capacity, priority can be assigned to data routers to for specific types of communication sessions (e.g. VoIP) to ensure bandwidth is available for voice communication.

Figure 25 shows how a data network shares bandwidth for both voice and data communications. This diagram shows that a single router is providing data communications service to IP telephones and computer workstations. In this example, a computer workstation is transferring a large file and the IP telephone is continuously sending a small amount of data (90 kbps). Because the LAN data network (Ethernet) has a maximum packet size of 1500 bytes of data and a standard high-speed data transmission rate of 100 Mbps, the router automatically divides the large file into smaller data blocks and access is shared between the IP telephone and the computer workstation. When the data packets arrive at the relatively low-speed WAN connection, congestion can occur. If congestion were to occur, the router connected to the WAN connection would begin to delay the transmission of packets. In this example, the WAN router gives priority to the voice over data network packets and delays the file transfer packets.

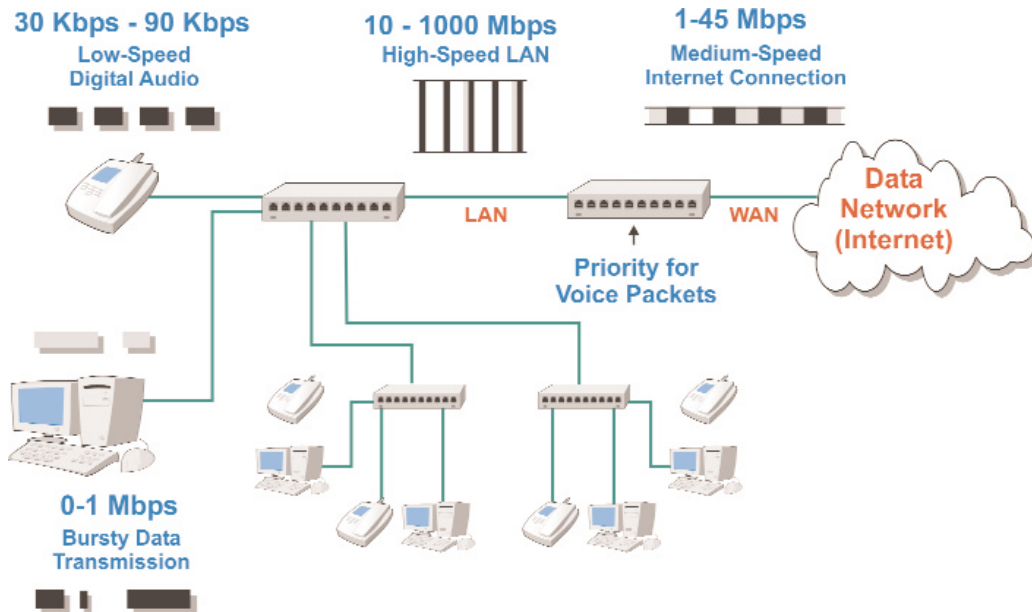

Figure 25, Sharing Bandwidth

## Number Portability – Keeping Your Telephone Numbers

The ability to keep your telephone numbers when you convert your telephone systems to voice over data (VoIP) systems is called number portability. The simple form of number portability for VoIP telephone service is call forwarding. More efficient forms of number portability are local, geographic, and service number portability.



## Introduction To IP Telephony

Call forwarding is a call processing feature allows a user to have telephones calls automatically redirected to another telephone number or device (such as a voice mail system). There can be conditional or unconditional reasons for call forwarding. If the user selects that all calls are forwarded to another telephone device (such as a telephone number or voice mailbox), this is unconditional. Conditional reasons for call forwarding include if the user is busy, does not answer or is not reachable (such as when a mobile phone is out of service area).

Figure 26 shows how call forwarding can allow you to keep your existing telephone number and use Internet telephone service. In this example, a customer has obtained a new Internet telephone number but they desire to keep their existing telephone number. The user simply calls the local telephone company and sets up the call forwarding number to the new Internet telephone number. Now when callers dial the old telephone number, the

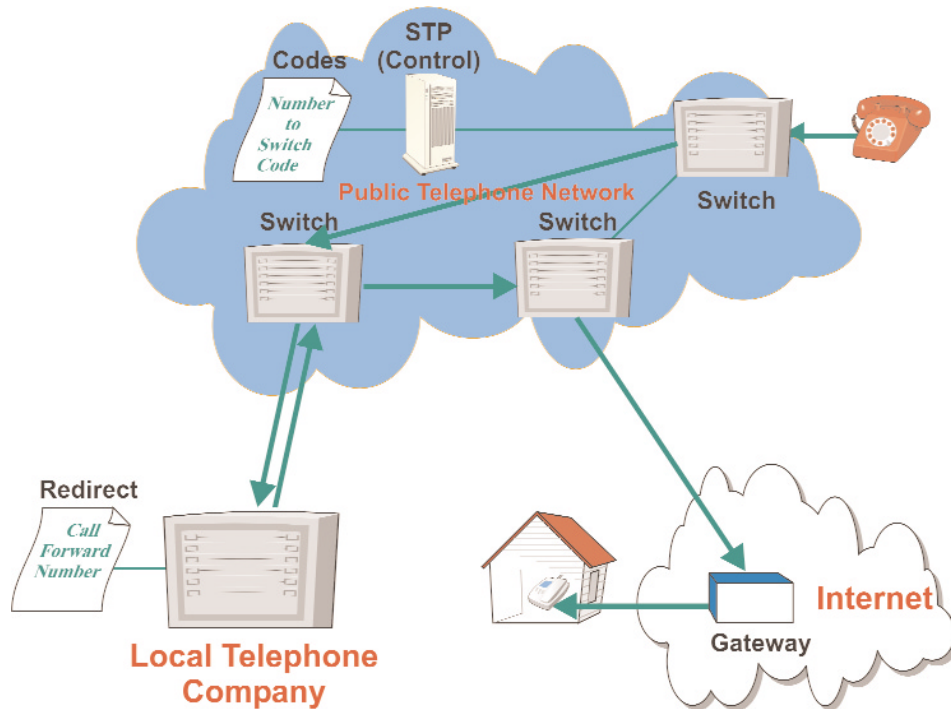

Figure 26, Call Forwarding to Internet Telephones

new Internet telephone will ring wherever the Internet telephone is plugged into the Internet throughout the world.

## **Number Portability**

True number portability involves three key elements: local number portability, service portability, and geographic portability. Local number portability allows a customer to change from one provider of local telephone service to another (typically to a competitive local exchange carrier – CLEC). Service number portability allows customers to change their number from one type of service (such as traditional telephone line) to a new type of service (such as mobile telephone service). Geographic portability allows a customer to take their number with them outside their local geographic area (such as between cities).

The different types of number portability can be complicated (and expensive) to perform in the traditional public telephone world because telephone numbers identify a location and often a type of device. The telephone number structure of country code, area code, exchange code, and extension (port) code help each telephone system to route the call towards its destination. Groups of telephone numbers are assigned to different types of companies (such as traditional landline or mobile telephone). The combination of location and service based telephone call connections cause challenges for number portability.

Implementing number portability requires a provider of telephone service to give up control of a telephone number, the public telephone network call connection lists must be updated, and the public telephone network must be able to reliably interact with the service associated with the new connection (such as Internet telephone service). If an ITSP is already a competitive local exchange carrier (CLEC), they already have access to the public telephone network and number portability may be possible. If not, it can be very expensive and complicated for an ITSP to offer number portability.

## Introduction To IP Telephony

Figure 27 shows how the basic steps to allow number portability for Internet telephone service. The first step is for the local telephone company to release the number from its system. Next, the public telephone network must update its directory lists (called point codes) of telephone numbers so the call will be routed to the company that provides interconnection services (such as an IP Centrex or ITSP company). Finally, the public telephone network must be reliably interconnected with the Internet telephone service provider to allow call setup and disconnections.

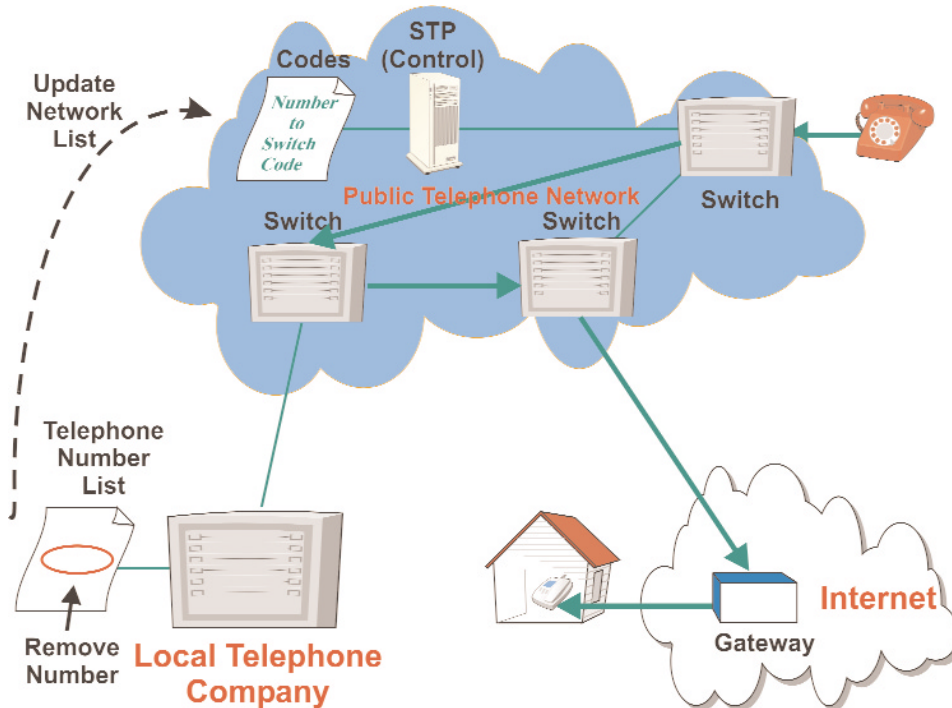

Figure 27, Internet Telephone Number Portability

## **Voice Quality, Security and Reliability**

The telephone network provides for a fairly high level of quality of service (QoS) and to be successful, Internet telephone service should have similar quality, security, and reliability.

The relatively good audio quality of telephone systems is called toll quality audio. To ensure security, public telephone networks restrict physical access to systems and have relatively tight network access control processes. The high reliability of public telephone networks is achieved through extensive standards, tests, and government regulations.

### **Audio Quality**

The measurement of telephone audio quality is subjective. Some of the key audio quality of service issues for Internet telephone service includes toll quality audio, control of echo, and the handling of audio distortion.

### **Toll Quality Audio**

The quality of telephone audio is measured by a mean opinion score (MOS). The MOS is number that is determined by a panel of listeners who subjectively rate the quality of audio on various samples. The rating level varies from 1 (bad) to 5 (excellent). Good quality telephone service (called “toll quality”) has a MOS level of 4.0.

Voice over data (VoIP) telephone service can provide toll quality audio (and in some cases better than toll quality). Public telephone networks directly digitize the voice and this provides for excellent voice quality. Voice over data telephone systems may use the same form of digitization as the telephone system (called G.711) or it may you a more efficient form of digital

## Introduction To IP Telephony

voice called speech compression. If the voice over data telephone service uses uncompressed digitized voice with reliable (guaranteed in some cases through private or managed data networks) data connections, the quality of audio will be as good or better than toll quality telephone service. It can be better than toll quality because voice over data telephone service digitizes the audio at the caller's location. The telephone network may digitize the audio connection at the switching center that can be miles away. An analog (non-digital) telephone line between the telephone and the switching center can accumulate noise signals (such as lightning noise spikes) that cannot be removed in the way that digital signals can remove the added effects of noise.

An early challenge for voice over data telephone audio quality was the excessive use of speech compression to increase the cost efficiency of connections and the use of low-speed data connections (such as Internet dial-up service). Generally, the more you compress the voice, the lower the audio quality. Recently, innovations in speech compression technology provide similar toll quality service using a much lower data communication (connection) speed. This allows for efficient voice over data telephone service to provide better than toll quality audio.

### **Echoes**

Echoes are a type of transmission impairment in which a signal is reflected (repeated) back to its originating source. In the transmission, the reflected signal often is attenuated (reduced in volume) and delayed, resulting in an echo.

Figure 28 shows a common cause of echo in voice over data telephone systems. This diagram shows how a telephone is calling an IP telephone that uses speakers and a microphone (speakerphone). Some of the audio from the speaker reaches the microphone and travels back to the caller. Because Internet telephone transmission takes some time, the audio signal that is returned to the caller is slightly delayed.

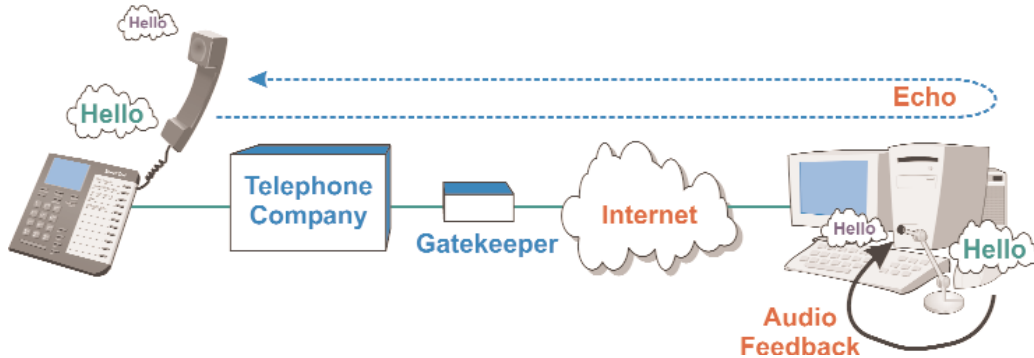

Figure 28, Causes of Internet Telephone Echo

In recent years, sophisticated audio processing equipment has been developed to allow the removal of echoes. By inserting this equipment into part of the communication network (called echo cancellers), echoes can be removed. The cost of echo canceling technology has decreased so much that echo-canceling processing is sometimes included in IP telephone handsets.

Figure 29 shows how an echo canceling system can remove echoes. In this example, the transmission of the words: “Hello, is Susan there” experience the effects of echo. When the signal is supplied to an echo canceller (a sophisticated estimating and subtraction machine), the echo canceling device takes a sample of the initial audio and tries to find echo matches of the input audio at delayed periods (the amount of echo time). In this example, it does this by creating various delayed versions the audio signal and different (reduced) amplitude (echo volume usually decreases as time increases), and comparing the estimate the audio that contains the echo. When it finds an exact match at a specific audio level, the echo canceller can subtract the echo signal. This produces audio without the echo.

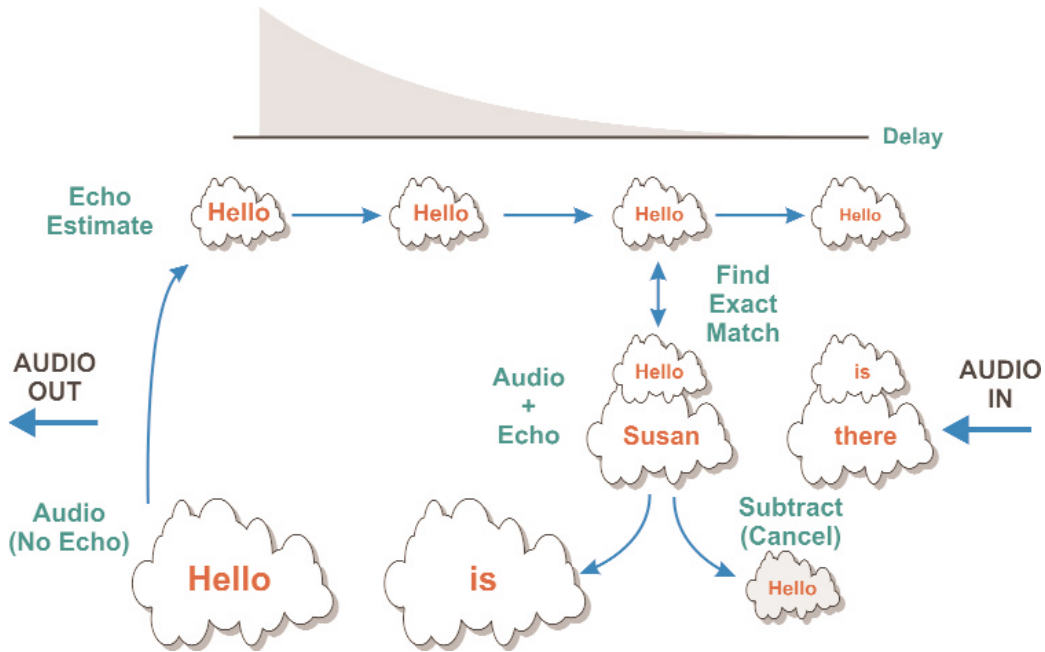

Figure 29, Echo Canceling

## Audio Distortion

Audio distortion is the undesired changing of an audio signal and it can come from a variety of sources in Internet telephone service. However, some of the key factors in audio distortion are packet loss, packet corruption, and echo.

Packet loss is the inability of the communication network to deliver a packet to its destination within a prescribed period of time. The effect of packet loss on audio distortion is to temporarily mute or distort the audio signal. Packet loss can result from a variety of events such as network congestion or equipment failures. Because audio communication systems require rapid delivery of packets of data, it is not usually possible or practical to resend packets of data that contain audio information. Because packet loss is infre-

quent and the packet size is relatively small, the loss of packets usually results in the temporary muting of information. In some cases, when a packet is lost, the missing segment may be recreated from the audio packet that is received from previous packets. Our voice does not change that much from packet to packet so we can repeat the previous packet to fill in the missing audio. As a result, if number of packets that are lost is relatively small, it is unnoticeable by the user.

Packet corruption is the changing of some of the packet data during its transmission. Packet corruption can come from a variety of sources such as poor communication line quality or momentary line loss from lightning spikes. Because voice over data telephone service may use speech compression (not all do), the packet data represents a sound that will be recreated rather than a specific portion of the actual audio signal. As a result, if corrupted data is used, this can create a very different audio sound than expected. This distorted sound is commonly called “Warble.”

Echo is a form of transmission signal impairment where some of the transmitted signal is reflected back to the originating source. There are several causes of echo in voice over data telephone systems. To reduce the effects of echo, voice over data telephone system equipment (gateways and IP telephones) may have one or more echo canceling devices to remove echo. However, the echo canceling process can also cause some distortion.

Figure 30 shows some of the causes and effects of audio distortion in voice over data telephone systems. This example shows that packet loss results in the temporary muting of the audio signal. Packet corruption results in the creation of a different altered sound than the sound that was previously transmitted. Echo results from some of the caller’s audio signal being sent back (audio feedback) by the receiver of the call.



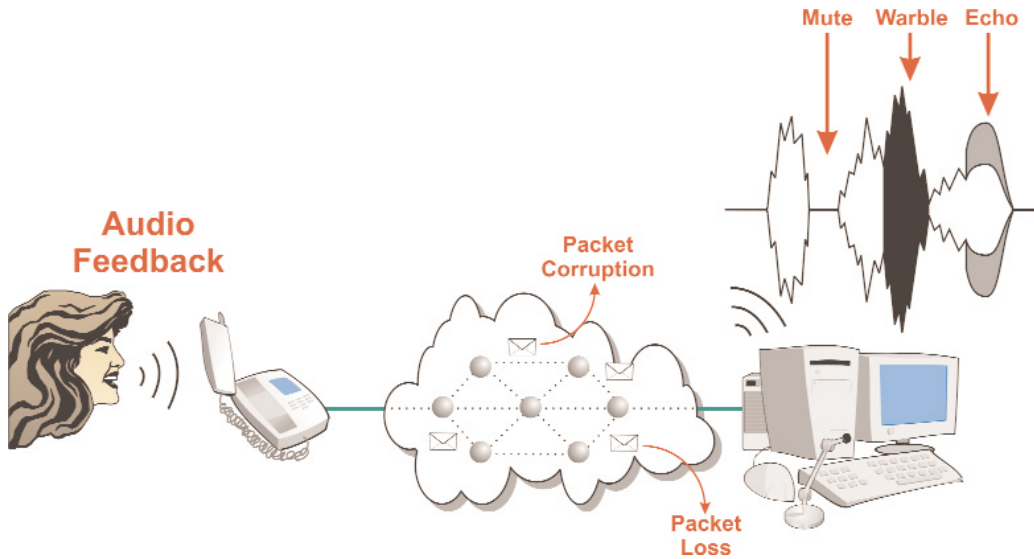

Figure 30, Internet Telephone Audio Distortion

## Security

Communication security involves the control of physical access to information, identity validation (authentication), service authorization, and information privacy protection (encryption).

## Physical Access

Physical access is the ability of a user or unauthorized user to physically send or receive information with a communication system or device. Gaining physical access to the to voice over data telephone service involves gaining physical access to the companies data network. If the company uses an

unmanaged public data network such as the Internet, physical access must be done before or after entrance or exit from the Internet connection. When packets travel through the Internet, they can take many different paths through the network so it would be very difficult to gather all the packets.

If you use wireless local area network (WLAN) for voice over data telephone service, it is important to turn on the Encryption feature. Use of wireless LAN provides easy physical access to nearby eavesdroppers.

Figure 31 shows that the typical physical access to Internet telephone service is usually limited to the connection points to and from the Internet. In this example, a cordless telephone is going through an analog telephone adapter gateway box. The gateway box is connected to the Internet service provider (ISP) through telephone wires that are mounted on the telephone poles. The ISP has a high-speed connection to the Internet that is also located on telephone poles. In this configuration, the radio signals between the cordless telephone and cordless base allow physical access by someone who is located within a few hundred feet within the cordless telephone. The physical access to the lines between the gateways and ISPs and ISPs to the Internet usually requires direction connection to telephone wires or data lines (such as coaxial cable). This example shows that once the Internet telephone call enters into the Internet, packets are usually routed through dif-

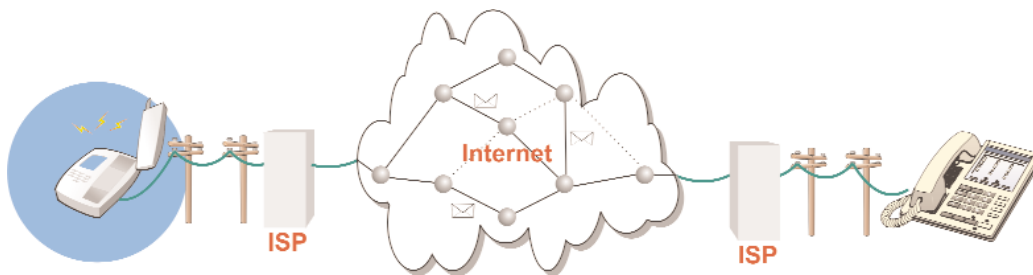

Figure 31, Physical Access to Internet Telephone Calls

## Introduction To IP Telephony

ferent paths. The only points that route all of the packets are the entry and exit points for the Internet. Physical access to all the packets is limited to these points.

### Authentication

Authentication is a process during where information is exchanged between a communications device (typically a user device such as an IP telephone or mobile phone) and a communications network that allows the carrier or network operator to confirm the true identity of the user (or device). The validation of the authenticity of the user or device allows a service provider to deny service to users that cannot be identified. Thus, authentication inhibits fraudulent use of a communication device that does not contain the proper identification information.

Figure 32 shows that Internet telephone authentication is typically divided into at least 2 parts, ISP authentication and ITSP authentication. For step 1, the ISP requires that a user identify them to the ISP prior to being provided access to the Internet. This may involve low security user identifica-

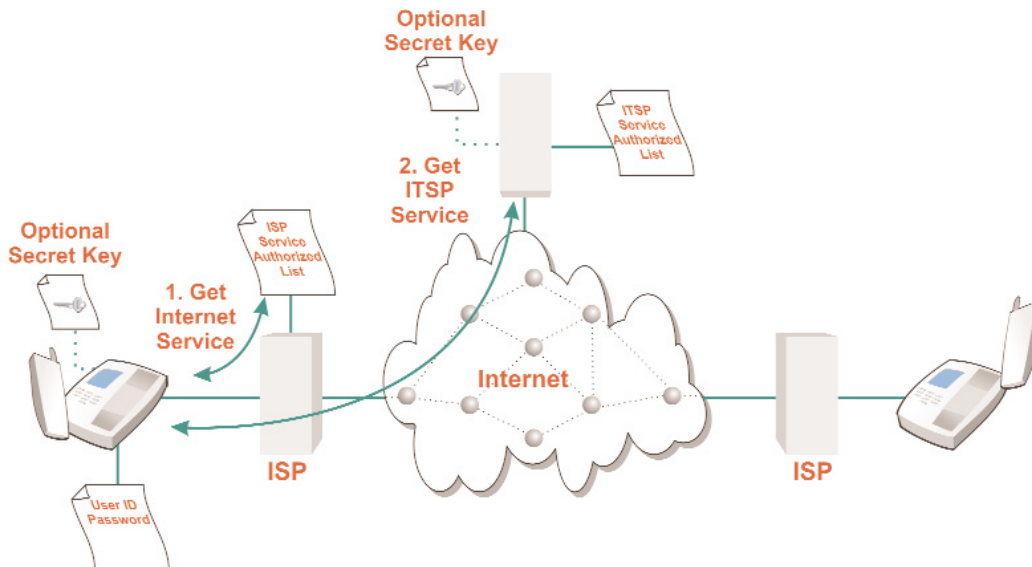

Figure 32, Internet Telephone Service Authentication

tion and password or it may involve a more secure authentication that requires the transfer of authorization codes. In step 2, the ITSP requires that the user identify them before being provided services from the ITSP. This also may involve simple identification and password or it may include the transfer of authorization codes.

## **Encryption**

Encryption is a process of protecting voice or data information from being obtained by unauthorized users. Encryption involves the use of a data processing algorithm (formula program) that uses one or more secret keys that both the sender and receiver of the information use to encrypt and decrypt the information. Without the encryption algorithm and key(s), unauthorized listeners cannot decode the message. When the encryption and decryption keys are the same, the encryption process is known as symmetrical encryption. When different encryption and decryption keys are used (such as in a public encryption system), the process is known as asymmetrical encryption. Encryption may be automatically provided between two points on a network. For example, on a cable modem, there is usually encryption between the cable modem and the cable network's connection to the Internet. This is important, as several users on the cable system will have physical access to the signals of other users on the cable network.

Figure 33 shows how voice over data telephone encryption may be used to protect information as it passes between callers via the Internet. This diagram shows two users that are sending encrypted (protected) packets of data to each other. To encrypt the data, the digital audio is processed (modified) using an encryption program (algorithm) and a key. When the encrypted data is received, the information is decoded using a decryption program (algorithm) and the key. If other users receive the encrypted packets, they cannot decode the information because they do not have the key.

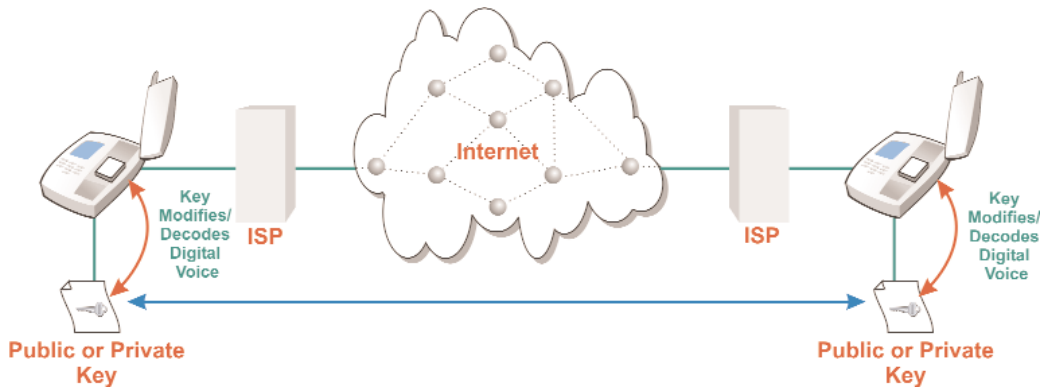

Figure 33, Encryption

## Reliability

Reliability is the ability of a network or equipment to perform within its normal operating parameters to provide a specific quality level of service. Reliability can be measured as a minimum performance rating over a specified interval of time. These parameters include bit error rate, minimum data transfer capacity or mean time between equipment failures (MTBF).

The reliability of the public telephone network is 99.999% system reliable (commonly called the “Five 9’s”). The public telephone network must be reliable because it is a lifeline service. Lifeline service assures a person can call for assistance or be contacted in the event of an emergency.

Reliability factors for Internet telephone service include IP telephone access device reliability, data network connection reliability, data network reliability, call server reliability, and feature operation reliability.

## Access Device Reliability

Access device reliability is the ability of device or system equipment to allow a user to gain access to a network within a specific quality level of service. For voice over data telephone service, the access device must be able to setup and receive calls and convert between audio and data packets.

To be effective, access devices must be able to continuously process audio and digital signals during a call. Access device operation may be dedicated (such as an IP telephone) or they may be shared (such as a PC telephone).

Access devices are often connected to a modem or local data network equipment. The reliability of these local data communication devices also affects the reliability of Internet telephone service. Some of these devices may change their configuration during connection and disconnection. If the data communication device does not appear to be working, it is best to turn its power off and restart the equipment.

Figure 34 shows that the selection of access device can affect the operation and quality of voice over data telephone calls. In this example, an Internet

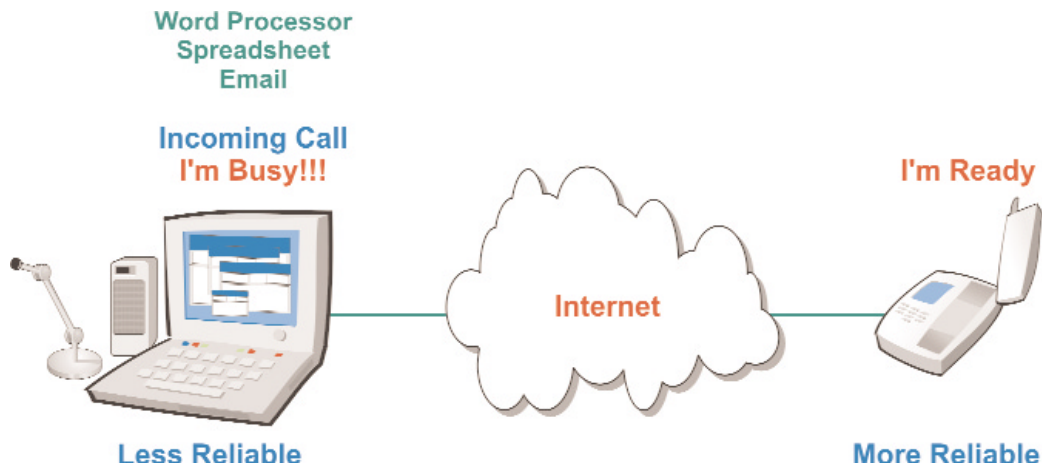

Figure 34, Internet Telephone Access Device Reliability

## Introduction To IP Telephony

phone is attempting to call a PC telephone through the Internet. The Internet phone is designed to perform one function, Internet telephone service and it always has the resources (processing power) to do this. Unfortunately, the PC telephone is a multipurpose device that is currently running several applications (word processor, spreadsheet, and email). When the computer receives this call, the other processes may cause the computer to miss the call (unlikely) or they may cause the audio to be somewhat distorted.

### **Data Network Reliability**

Data network reliability is the ability of the communication network to consistently provide data transmission between points that are connected to the data network. Data networks such as the Internet were designed to successfully operate even if large portions of the network were destroyed. To accomplish this, the Internet was designed as a dumb network that uses smart switches. Each switch in the Internet (called a router) has the ability to dynamically change the path it uses to sending data through based on information it regularly receives from other routers. If a router can no longer send data to a neighboring router, it will automatically start to send data to a router it can communicate with. As a result, the Internet is very reliable as it can repair itself in the event equipment failures.

Figure 35 shows that the Internet is a web of paths that interconnect endpoints and that if this web is broken, it is possible for information to take another path to reach its destination. This rerouting of information is automatic.

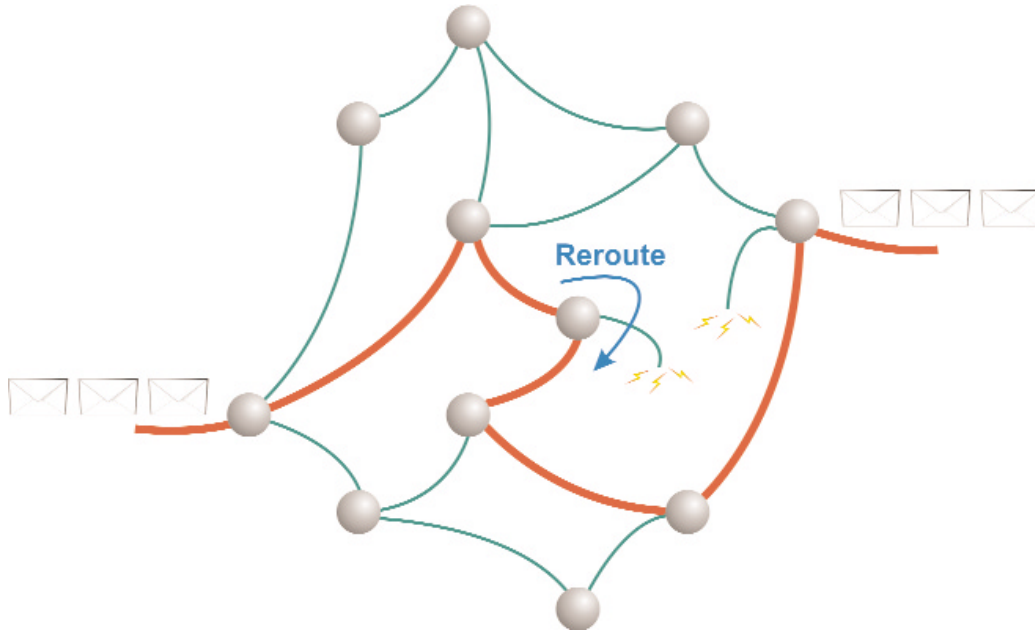

Figure 35, Internet Reliability

### Data Connection Reliability

Data connection reliability involves the connection from your computer or IP telephone to the data network (such as the Internet). Your data connection may be divided into two parts; access provider and data network provider (such as an ISP). The access provider manages the connection between your equipment and the data network provider converts your data into a format that it can transmit through the data network.

Figure 36 shows the key parts of an Internet service provider (ISP) and how they can affect your communications reliability. This diagram shows that an Internet connection can be divided into an ISP portion and an access portion. This example shows an Internet telephone that is connected to a cable modem. The cable modem is connected to the head-end of the cable television system where a gateway adapts the data from the cable network into a



## Introduction To IP Telephony

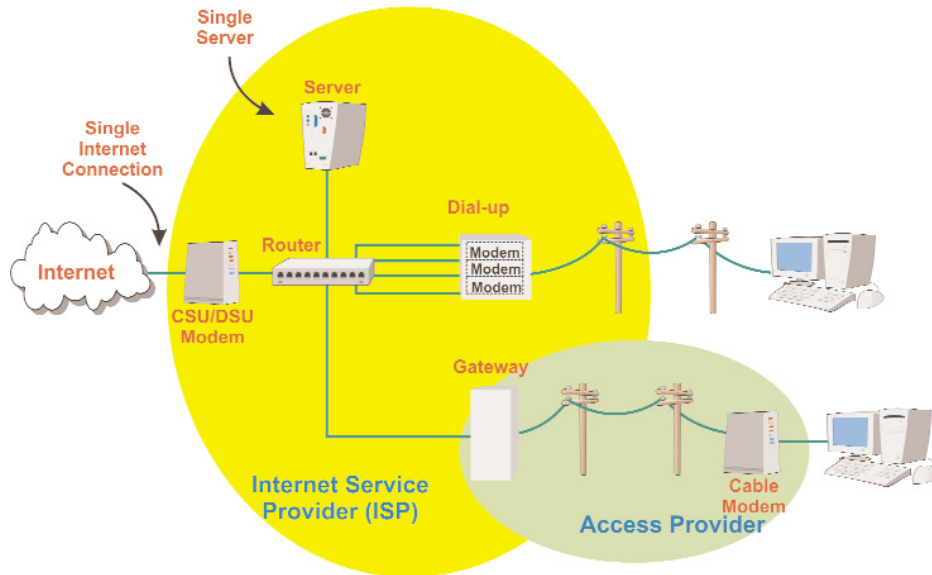

Figure 36, ISP Reliability

format that can be used by the ISP. The ISP has a router that connects the gateway into a format that is sent to the Internet. This diagram shows that this ISP only has on connection to the Internet and if it experiences difficulty, the Internet connection can be lost.

### Call Server Reliability

Call server reliability includes the ability of a call server (call processing computer) to setup and control calls along with selecting and managing gateways. To ensure reliability, call servers may have redundant (duplicate) server equipment, updated lists of audio gateways, and use equipment that confirms to specific and compatible revisions of communication protocols.

Figure 37 shows the key parts of a call server that is used to provide Internet telephone service and how the configuration can affect reliability. In this example, the ITSP call server has two call processing centers that are connected to the Internet at different locations. Internet telephones communicate with the ITSP servers to setup and receive calls. Each sever has a gateway list that comes from a company that maintains lists of gateways (a clearinghouse). In the event of a failure of one of the servers, the other server will operate to setup and connect calls.

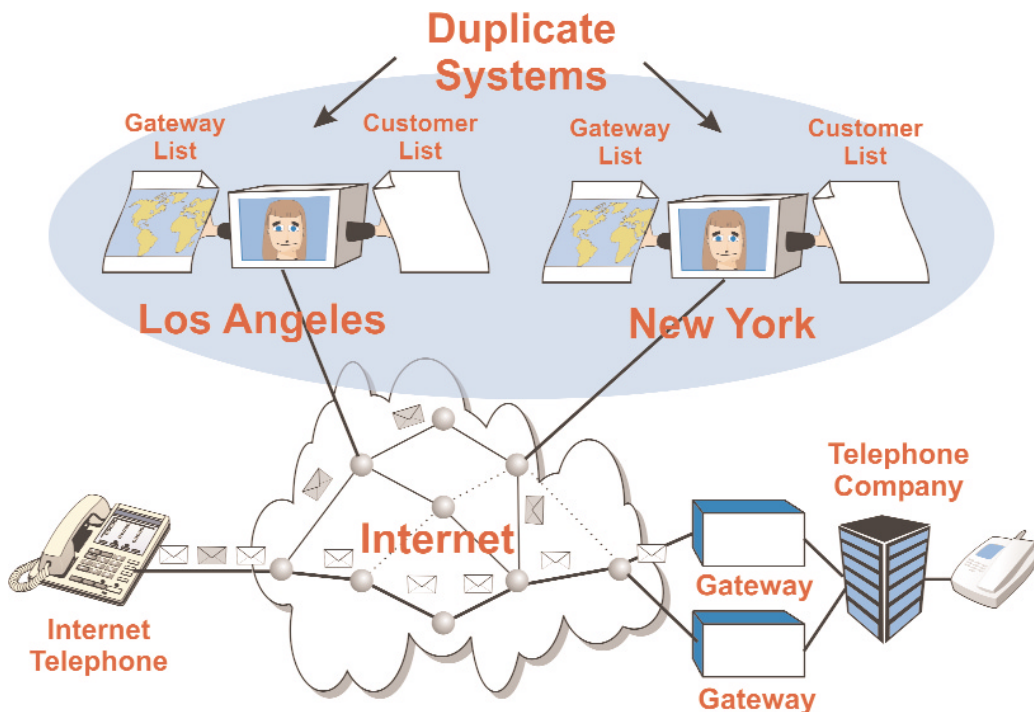

Figure 37, ITSP Reliability

## **Feature Operation Reliability**

Feature operation reliability is the ability of the system to recognize and process feature requests. There are many features available in the public telephone networks and these features have been designed and tested to interoperate with each other. These features are usually managed by a single system. When these features are offered via ITSPs, there may be interaction with these features with features offered by different service providers. This can cause challenges with the operation of specific features. For example, if an ITSP provides a free voice mailbox and you have an answering machine, if you do not answer the call, it may be automatically routed to the voice mailbox provided by the ITSP.

## Advanced Features and Services

In addition to providing the essential telecom service features, voice over data (VoIP) telephone service can perform advanced features such as unified messaging, anywhere extensions, global telephone numbers, videophone, simultaneous whiteboard displays, audio conferencing, and distant learning through Webinars.

### Unified Messaging

Unified messaging is a multimedia messaging system (MMS) that allows you to store, manage, transfer, and retrieve different forms of messages. Unified messaging systems manage audio (voice messages), electronic mail (email), data messages (such as fax or files), and digital video (video mail). Unified messaging provides you with access to these multiple types of messages using standard telephones, (text to audio); Internet web pages (playing back voice messages), and other devices such as fax machines and mobile telephones.

Multiple voice mailboxes can be difficult to manage. If you have multiple voice mailboxes and you use call forwarding to another number that has voice mail, set the call forwarding time on your call shorter (5-10 seconds) than the time for the first voice mailbox is set to answer. This will ensure that your 2<sup>nd</sup> line (perhaps a mobile telephone) will get transferred to its voice mailbox. This will allow you to check only one voice mailbox for all your messages.

Figure 38 shows that the key parts of a unified messaging system are access devices, storage system, and unified messaging services (programs). This diagram shows that there are several ways to access and receive information from the unified messaging system including pagers, wireless tele-

## Introduction To IP Telephony

phones, standard (wired) telephones, email, faxes, and web pages. The core of the unified messaging system is a digital message storage and retrieval system. This system can provide various services and in this example, it includes voice mail, fax mail, e-mail, text-to-audio, operator-to-audio, and

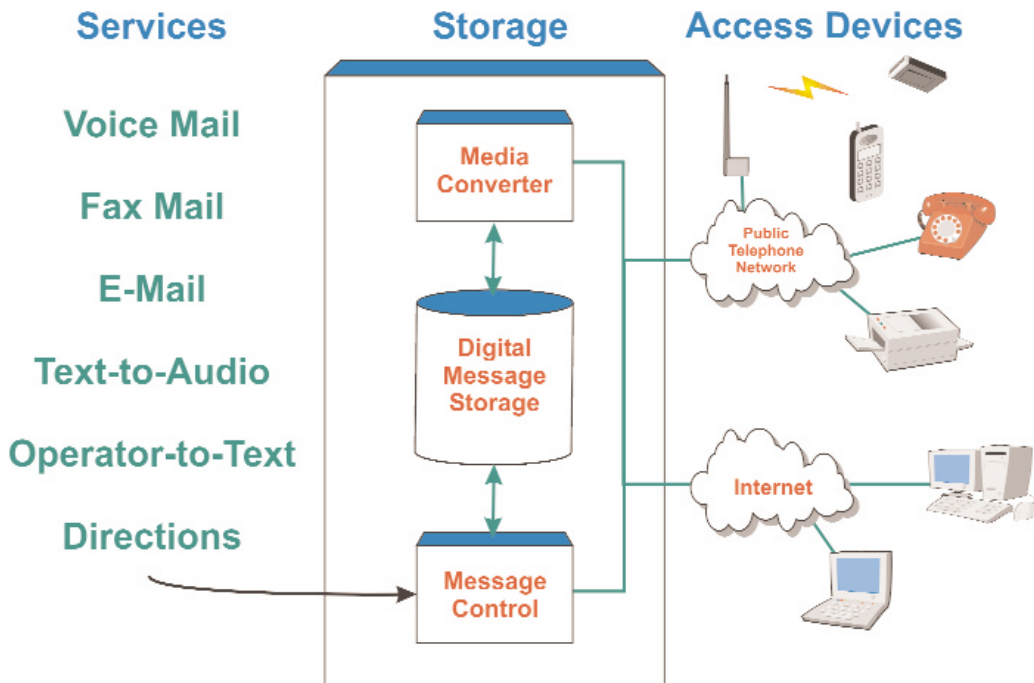

Figure 38., Unified Messaging

directory information services. The digital storage system is accessed via a media converter processing assembly. This processor is capable of converting audio to data, data to audio, and transforming data from one format (such as a email) to data of another format (such as a fax page). The system operation is controlled by the use of feature programs and the requests received from the access devices (such as receiving a play message).

Figure 39 shows Spherically™ Voice mail from Sphere Communications that integrates voice mail, auto attendant and unified messaging system available with the Spherically IP PBX. This is a software application that provides

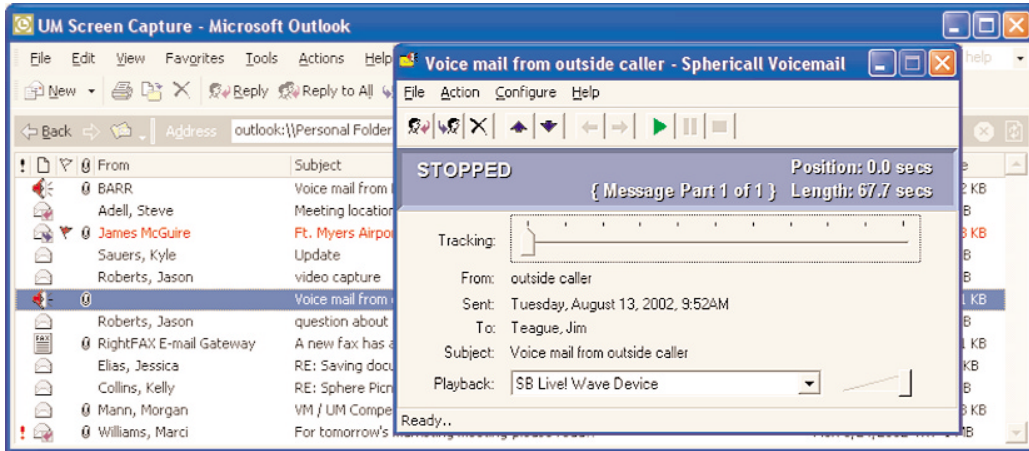

Figure 39. Unified Messaging Screen  
Source: Sphere Communications Inc.

unified messaging services for an entire corporate communications network. Some of the key features of this unified messaging system is auto attendants, voice mail, and distributed message processing.

## Anywhere Extensions

Telephone extensions are communication devices that are connected to a telephone system. These connections may be shared (several telephones on the same line) or they may be independently controlled (such as in a private telephone system). Traditionally, telephone extensions have a fixed wire or a connection line. This allows a telephone device to either share (directly connect to) another communication line or to allow it to independently connect it to a switching point (such as a private company telephone system).

When an Internet telephone is first connected (plugged-in) to a data connection, it requests the assignment of a temporary Internet address from the data network. It uses this Internet address to register with the ITSP

## Introduction To IP Telephony

after it has been connected to the Internet. Because the ITSP always knows the current Internet address that is assigned to the Internet telephone each time it has been connected to the Internet, this allows Internet telephones to operate at any connection point that is willing to provide it access to the Internet. In essence, this allows an Internet telephone to operate like a telephone extension that can be plugged in anywhere in the world.

Figure 40 shows how Internet telephones can be located anywhere they can be connected to the Internet. In this example, this company uses Internet telephones that are connected to its headquarters near New York City. Extension to the company phone system can be located anywhere in the world. This example shows that x101 is in the corporate office in New York, x102 is located in Boston, x103 is located in Tokyo, and x104 is located in Beijing. When extension 102 dials 103, the call is automatically connected through the Internet from Beijing to Tokyo.

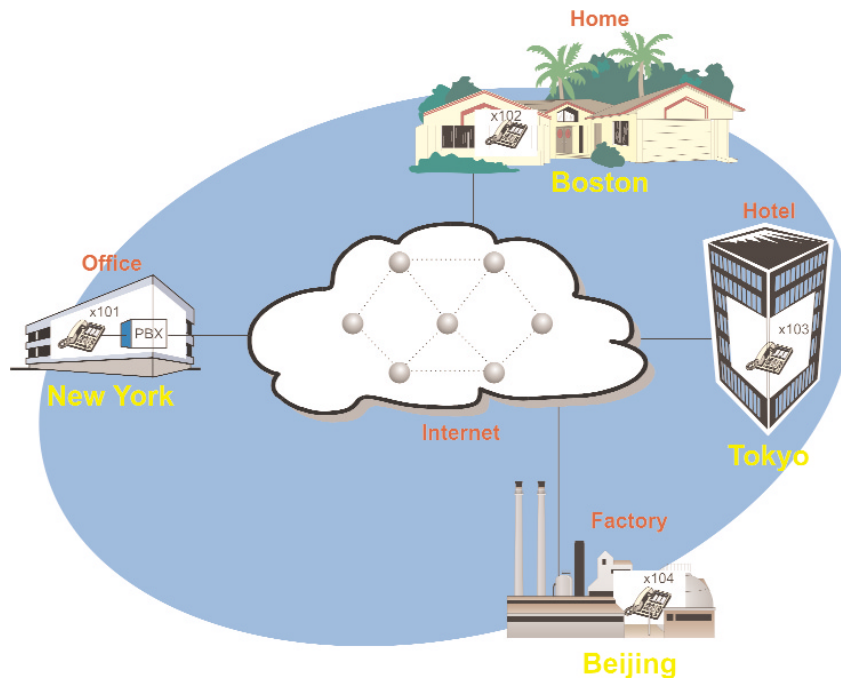

Figure 40, Internet Telephone Extensions go Anywhere

What makes this so interesting is that these handsets can be taken anywhere and they will continue to operate as if there were no changes. Supposed the person in the New York office (x101) were to take their phone with them to a hotel in Italy. When they plug the phone into the Internet in Italy, it will operate just as it was in the corporate office in New York. It does this because the phone registers with the corporate office when it is plugged into the Internet. The Internet address of each IP telephone is dynamically assigned each time they are turned on and the corporate office keeps track of these addresses. It doesn't really matter where the IP telephone is plugged in.

## **Global Telephone Numbers**

You can get one (or several) international telephone numbers that connect to ("ring") your Internet telephone wherever you have it plugged in. If you have friends or customers in the United Kingdom, Brazil, or Japan, they can simply dial a local Internet telephone number in their area and call you. When the call is received at the local number, it is converted to Internet data and routed to your Internet telephone wherever you have connected (plugged-in) the Internet telephone. The typical call charge you may incur is the conversion cost of the local call to Internet data.

Companies may charge more for service when you register in a country outside their area. If you have a friend in a country with a low billing rate (such as the United States), use their address for the account setup. Once you have service, it does not matter where you install your Internet telephone.

Figure 41 shows how a person or company can get a telephone number in another country. In this example, a person in Paris gets a telephone number in New York City (area code 212). When a local caller dials the Internet telephone number, the call is connected to the Internet telephone that is located in Paris. The caller in New York City is paying for a local call and the connection between New York City and the Internet telephone in Paris is free.



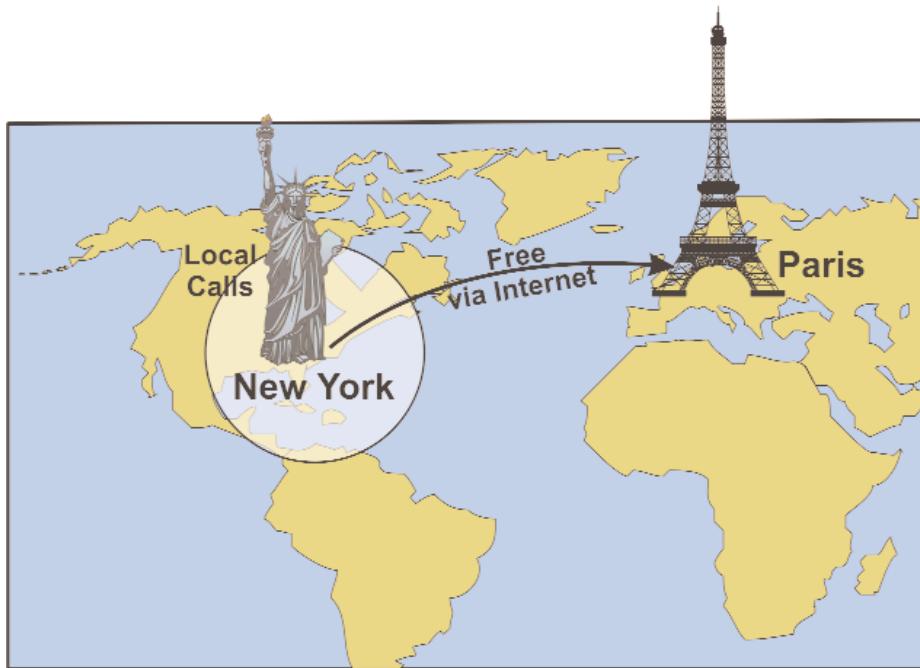

Figure 41., Using Internet Telephone for International Telephone Numbers

## Videophone

A videophone is a communication device that can capture and display video information in addition to audio information. A videophone converts multiple forms of media, audio and video into a single transmission format (such as Internet protocol). The use of videophones with an Internet telephone service allows the video portion of the communications session to share the data connection.

Figure 42 shows the InnoMedia IP VideoPhone (all-in-one video conferencing system). This multimedia phone uses Internet protocol (IP) to provide desktop video conferencing telephone. It integrates video images with key telephone features like speakerphone, mute, last number redial and an on-screen phone book into a system that is as easy to use as a standard phone. Through the use of data compression, it only requires a 64 kbps to 192 kbps IP connections to provide video conferencing service. It has a built-in 4" LCD



Figure 42, Video Phone  
Source: Innomedia

screen and high quality CCD camera. It can interoperate with industry standard H.323 gateways and gatekeepers and supports multi-party video conferencing with external MCU. It can also be remotely upgraded and configured through a web browser.

## Whiteboard

A whiteboard is a device that can capture images or hand drawn text so they can be transferred to a video conferencing system. Whiteboards allow video conferencing users to share images and/or hand written diagrams with one (or more) videoconference attendees.

## Introduction To IP Telephony

Figure 43 shows how a whiteboard can be used during an Internet telephone call to transfer hand drawn images. In this example, an instructor is drawing a diagram on a white pad. While the instructor is drawing, the image is being displayed on both the instructors monitor and the students monitor.

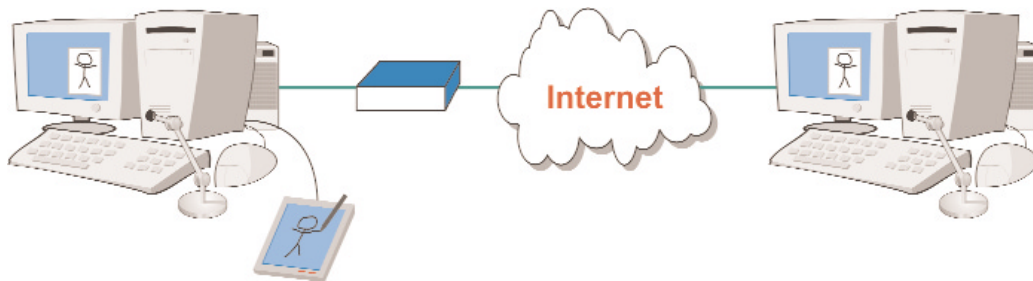

Figure 43, Whiteboard Operation

Figure 44 shows an InterWrite meeting electronic whiteboard that allows presenters to use an electronic pen to draw images on the screen. These images can simultaneously be seen around a conference table or anywhere around the world that has the appropriate data or Internet web connections. It allows the presenter to communicate and interact with an unlimited number of users and sites. This system works with web seminar (Webinar) systems such as WebEx.



Figure 44, Whiteboard Screen  
Source: GTCO CalComp

## Audio Conferencing

Audio conferencing (also called teleconferencing) is a process of conducting a meeting between two or more people through the use of telecommunications circuits and equipment. This permits callers from several diverse locations to be connected together to share a common (conference) call.

To enable an audio conference call, an audio bridge is used to amplify and balancing the loudness of each speaker in a conference call so everyone can hear each other and speak to each other. During the call, background noises are suppressed from non-talkers only the current (one to three) loudest speakers' voices are retransmitted to other participants by the bridge. Each callers voice audio is not sent back to that speaker to avoid audio feedback, echo or "squealing" self-oscillation.

## Introduction To IP Telephony

Background noise can interfere with audio conferencing. Audio conferencing systems reduce the audio volume of users when others are talking. Background noise may confuse the audio conferencing system and it may adjust (lower) the volume of the speaker. You can reduce your background noise by using a directional microphone or by selecting the mute button on your telephone.

Figure 45 shows how a conference call can use a conference bridge to allow several users to effectively communicate in a conference call (3 or more users). This example shows that this conference bridge uses audio level detectors to determine the level of the microphone audio level for each conference call participant that is talking. As a person begins to talk, the conference bridge increases the gain on the microphone and decreases the gain on the speaker line. This process effectively dynamically reduces the background noise from non-participating members while providing good sound quality to participants that are talking.

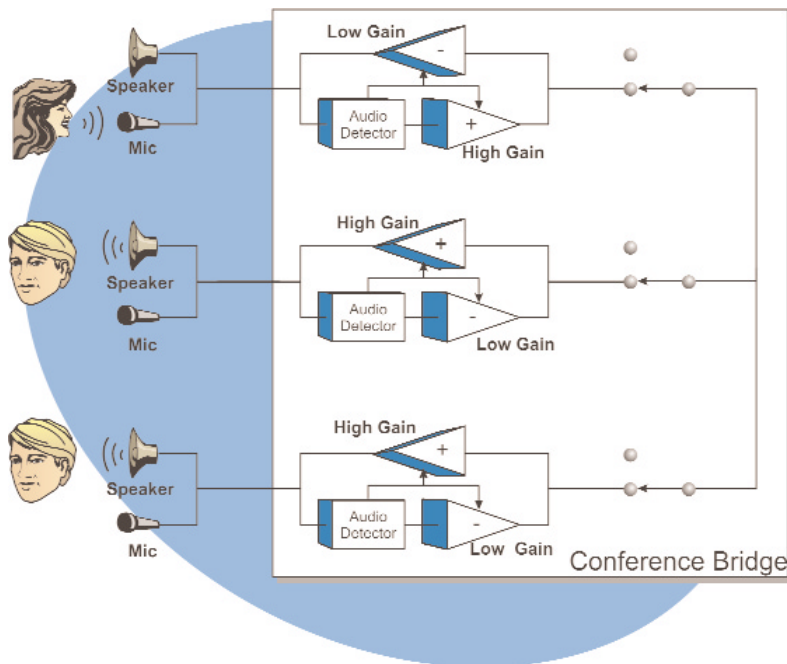

Figure 45, Audio Conferencing

## Audio Chat Rooms

Audio chat rooms are real-time communication services that allow several participants (typically 10 to 20) to interact act much like an audio conference session. Audio conference chat rooms may be public (allow anyone to participate) or private (restricted to those with invitations or access codes.)

Audio chat rooms are a little different than audio conferences. Audio chat rooms often allow simultaneous text messaging with audio conversation and they typically allow one speaker at a time. Aggressive participants can also be restricted from speaking based on feedback from the other participants. Each member in the audio chat room takes a turn at talking. To talk, they either press the Talk button or set the hands free to automatically transmit a request to talk. If nobody else is talking, their request to talk may be acknowledged and all the other participants will hear what the talker is saying. If another participant requests to talk while someone else is already talking, his or her request will be rejected.

The audio microphone volume of your Internet telephone may be very high when used in audio chat rooms. This can annoy chat room members and it may result in the members voting that your privileges of participation to be removed.

Figure 46 shows audio chat rooms can operate. In this example, there are several people participating on in Internet telephone chat session. This chat session screen is divided into several smaller windows. The main window is the messaging screen that shows text messages from each participant. The window to the right shows the participants in the chat session. The icon next to each participant (face with or without headset) shows which members have audio and video capability. This screen allows the user to talk by pressing the talk button or by selecting the hands-free option. A display on the bottom is also provided to indicate which participant is talking.

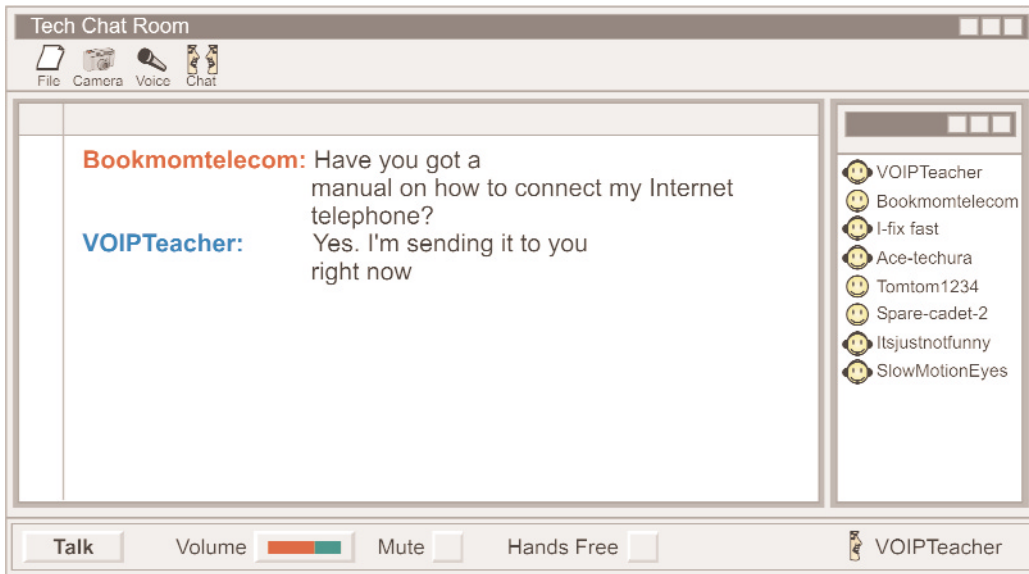

Figure 46, Audio Chat Rooms

## Web Seminars (Webinars)

Webinars are seminars or instruction sessions that use the Internet Web as a real time presentation format along with audio channels (via web or telephone) that allow participants to listen and possibly interact with the session. Webinars allow people to participate in information or training sessions from anywhere that have Internet and audio access.

Figure 47 shows a Webinar page from The Billing College that is presenting a telecom billing training course. This web page shows that a typical Webinar display has several active screen (window) areas. The main window area shows the student the slides of a presentation and the instructor controls the selection of these slides. The user can enlarge and shrink this window throughout the session. An additional Webinar window also provide the user with information about the presenter, lists of other participants, and includes an area that allows for text messaging between the student and the instructor.

# Introduction To IP Telephony

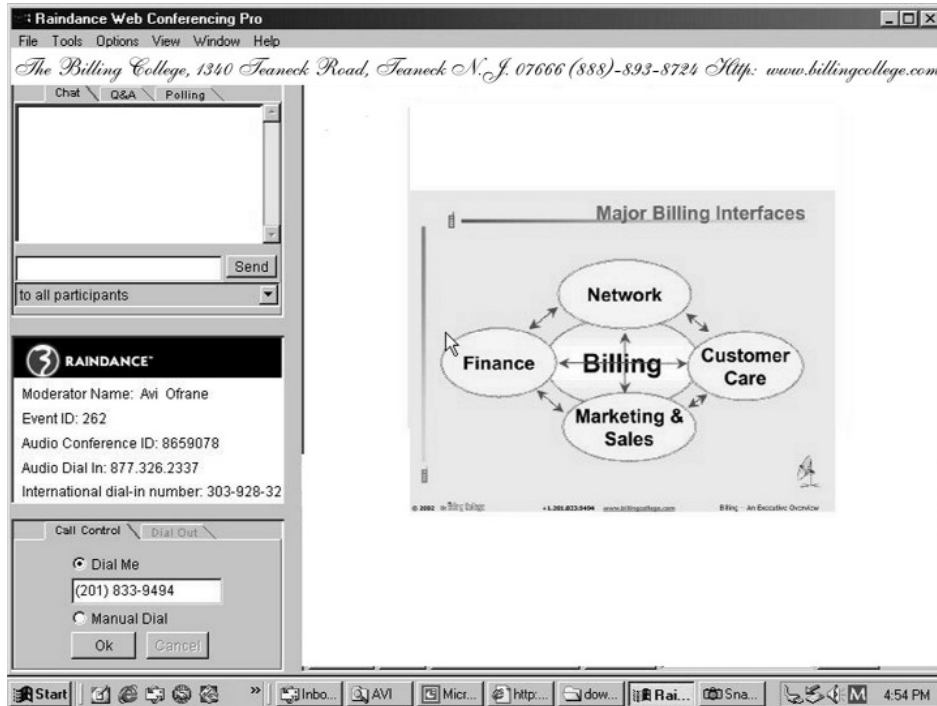

Figure 47, Webinar Training Screen  
Source: The Billing College